

STATE OF SOUTH DAKOTA
BROOKINGS COUNTY

PLANS FOR PROPOSED
City of Brookings – Parks, Recreation,
and Forestry Department
Pickleball Courts Project

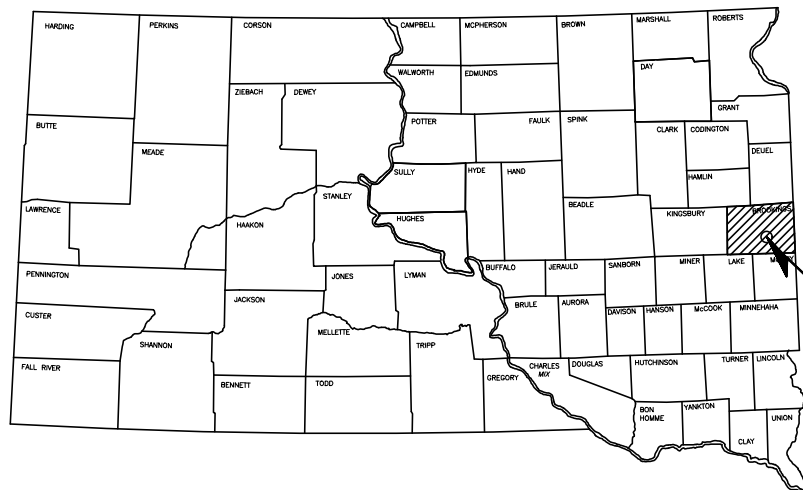

PROJECT LOCATION
Brookings, South Dakota

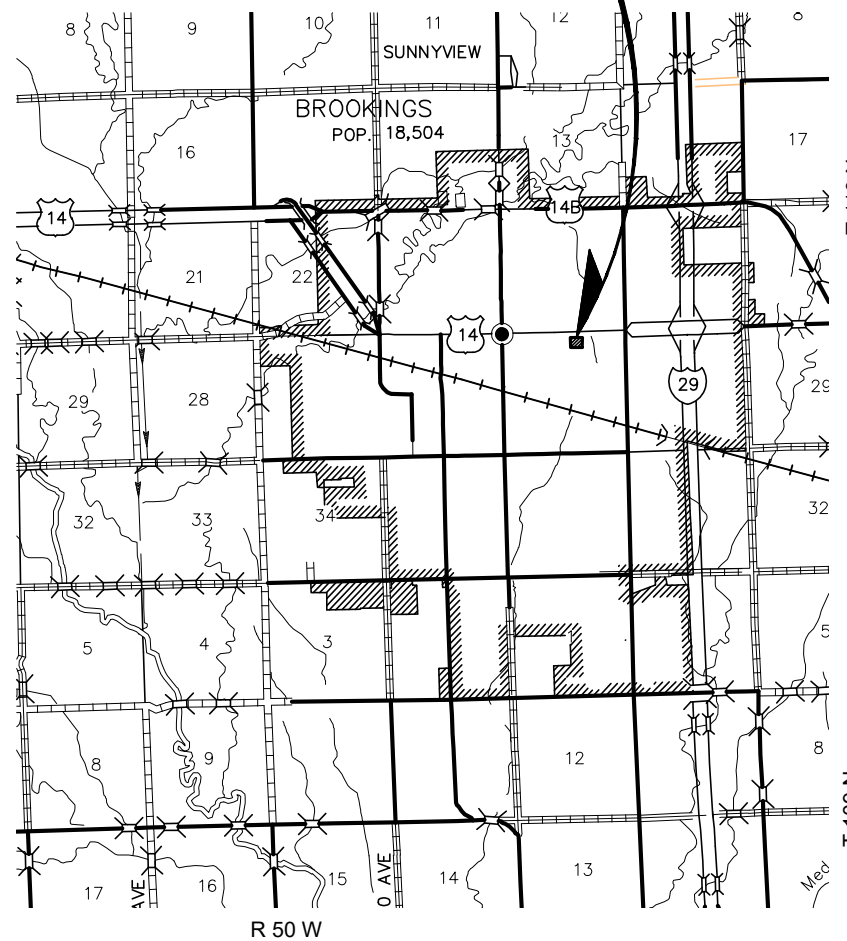

INDEX OF SHEETS

Sheet No.	Description
1	Title Sheet
2	Estimate of Quantities
3-9	Notes & Specifications
10	Existing Conditions, Removals and Erosion Control
11	Erosion Control Details
12	Proposed Site
13	Proposed Grading
14	Proposed Utilities
15-17	Details
E000	Electrical Symbols & Abbreviations
E001-E002	Electrical Specifications
E101	Electrical Site Plan
E601	Lighting Calculations
E801	Electrical Schedules

Note: Electrical Plan Sheets removed with no award of Base Bid B - Schedule F - Lighting.

CONFORMED PLANS

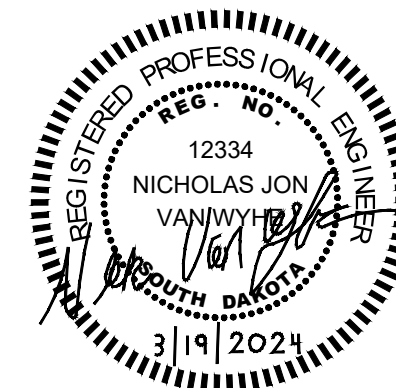

P:\Brookings\Projects\City of Brookings\2023_055 Brookings - Pickleball Courts\Design\Final Design\Final Design\Final.dwg, Title Sheet, 3/19/2024, 11:13 AM, Cole Bangard

Estimate of Quantities

Base Bid A - Schedules A-E

SCHEDULE A - MOBILIZATION, REMOVALS, GRADING, AND SURFACING			
BID ITEM NUMBER	DESCRIPTION	UNIT	QUANTITY
A-1	Mobilization	LS	Lump Sum
A-2	Remove Storm Sewer Pipe	LF	186
A-3	Unclassified Excavation	CY	2,845
A-4	Placing Topsoil (8")	CY	150
A-5	Scarify & Recompact (1-Ft)	CY	700
A-6	Non-Frost Susceptable Fill	TON	5,700
A-7	Aggregate Base Course	TON	550
A-8	5" Concrete Sidewalk	SF	2,096
A-9	Woven Geotextile Fabric	SY	2,020
A-10	Post-Tensioned Concrete Pavement	SF	16,600

SCHEDULE B - STORM SEWER			
BID ITEM NUMBER	DESCRIPTION	UNIT	QUANTITY
B-1	15" PVC, SDR 35, Furnish & Install	LF	260
B-2	18" Nyloplast Drain Basin W/ Grate, Furnish & Install	EA	3
B-3	4" HDPE Drain Tile w/Sock, Furnish & Install	LF	309

SCHEDULE C - COURT SURFACING			
BID ITEM NUMBER	DESCRIPTION	UNIT	QUANTITY
C-1	Liquid Applied Acrylic Surface (2 Filler Layers, 2 Color Coats)	LS	Lump Sum
C-2	Court Markings and Striping	LS	Lump Sum
C-3	Netting System	EA	8

SCHEDULE D - CHAIN-LINK FENCE			
BID ITEM NUMBER	DESCRIPTION	UNIT	QUANTITY
D-1	4' Black Vinyl Coated Chain-Link Fence	LF	558
D-2	48" Black Vinyl Coated Chain-Link Gate (4' Height)	EA	8
D-3	48" Black Vinyl Coated Chain-Link Gate (8' Height)	EA	2
D-4	72" Black Vinyl Coated Chain-Link Gate (8' Height)	EA	1
D-5	8' Black Vinyl Coated Chain-Link Fence	LF	503

SCHEDULE E - EROSION CONTROL			
BID ITEM NUMBER	DESCRIPTION	UNIT	QUANTITY
E-1	Silt Fence	LF	707
E-2	Inlet Sediment Control Device	EA	4
E-3	Concrete Washout Area	EA	1
E-4	Permanent Seed Mixture	LB	95
E-5	Fertilizer	LB	190
E-6	Fiber Mulching	LB	680

Base Bid B - Schedule F

SCHEDULE F - LIGHTING			
BID ITEM NUMBER	DESCRIPTION	UNIT	QUANTITY
F-1	Lighting System, Furnish & Install	1	Lump Sum

Note: Plan Sheet Includes Revised Layout and Quantities.

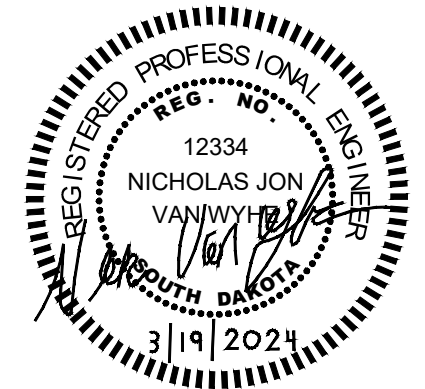

SCOPE OF WORK

Base Bid A - Schedules A-E: Work included in these documents will consist of construction for an outdoor Pickleball Court for the City of Brookings, including but not limited to: site removals, site grading, subgrade preparation, installation of drainage components, placing fill material, placing base course, placing PCC sidewalk, placing Post-Tensioned PCC pavement, installation of athletic surfacing, court line markings, installation of court netting systems, and chain-link fencing installation.

Base Bid B - Schedule F: Work includes installation of electrical components for court lighting system.

Specifications

South Dakota Department of Transportation Standard Specifications for Roads and Bridges, 2015 Edition and Required Provisions. Supplemental Specifications and/or Special Provisions as indicated in the Proposal.

The SDDOT Specification and provisions can be found at:

<http://www.sddot.com/business/contractors/specs/2015specbook/Default.aspx>

American Sports Builder Association (ASBA)

Post-Tensioning Institute (PTI)

USA Pickleball Association (USAPA)

Milestone & Completion Dates

Start Date: The Contractor will be allowed to start as soon as the frost comes out and site conditions are suitable for construction (assuming all bid documents are received). The Contractor will be required to have all erosion control items fully installed prior to starting the Work. The Contractor shall begin Work and continue until completion without breaks or delays in the progress of the Work. Base Bid A and Base Bid B shall have the the completion dates stated below.

Substantial Completion: **August 30, 2024.**

Final Completion: **September 20, 2024.**

Substantial Completion: All phases of Work shall be substantially completed by August 30, 2024. Substantial Completion shall be defined as all Work included in the Contract completed, except final topsoil grading, seeding, and punchlist items. Rough grading of the topsoil will be required in order to eliminate drop offs and hazards next to the sidewalk and playing surfaces. Substantial completion will not be considered until all concrete pavement is completed, all court surfacing installed, all netting systems installed, and all electrical and lighting is operational, and other incidentals completed to allow use of the playing surface.

Contractor Cooperation

Due to the nature of the project, multiple contractors may be on site at the same time. Contractors must cooperate to assure that all projects are completed by their contractually stipulated completion dates. Contractors shall respect the working environment of other contractors and communicate to avoid conflicts which would result in delays to the project.

Submittals

Prior to ordering any materials for concrete pavement, concrete surfacing, storm sewer, fencing, and electrical items, the Contractor shall submit one set of shop drawings, product data sheets, and material certifications to the Engineer for approval (See General Conditions).

Utilities

Utilities within the limits of the proposed construction are to be adjusted by the Owner unless otherwise indicated on these plans. Existing utilities indicated on the plans are approximate and are shown for the Contractor's convenience and information. The Engineer does not guarantee that the utilities shown include all such facilities that may exist on site, nor the locations indicated are exact. The Contractor shall contact South Dakota One Call at 800-781-7474 a minimum of two working days prior to any underground work to determine utility locations. The Contractor shall protect all existing utilities. Any damage to existing utilities caused by Contractor carelessness shall be repaired at the Contractor's expense to the satisfaction of the utility owner.

Clearing

Before clearing activities begin, the Contractor shall contact the Engineer to determine the limits of clearing for the project. If the trees or shrubs that are suppose to remain within the limits of work are damaged or destroyed by the Contractor, the Contractor shall replace them with the same size and type at the Contractor's expense.

Water Source

The Contractor will not withdraw water with equipment previously used outside the State of South Dakota or previously used in aquatic invasive species (AIS) positive waters within South Dakota without prior approval from the Project Engineer. To prevent and control the introduction and spread of invasive species into the project vicinity, all equipment will be power washed with hot water (≥140 °F) and completely dried for a minimum of 7 days prior to subsequent use. South Dakota administrative rule 41:10:04:02 forbids the possession and transport of AIS; therefore, all attached dirt, mud, debris and vegetation must be removed and all compartments and tanks capable of holding standing water must be drained. This includes, but is not limited to, all equipment, pumps, lines, hoses and holding tanks.

The Contractor will not withdraw water directly from streams of the James, Big Sioux, and Vermillion watersheds without prior approval from the Project Engineer.

Action Taken/Required:

The Contractor will obtain the necessary permits from the regulatory agencies such as the South Dakota Department of Agriculture and Natural Resources (DANR) and the United States Army Corps of Engineers (USACE) prior to water extraction activities.

Additional information and mapping of water sources impacted by Aquatic Invasive Species in South Dakota can be accessed at:

<https://sdleastwanted.sd.gov/>

South Dakota Aministrative Rule 41:10:04 Aquatic Invasive Species:

<https://sdlegislature.gov/rules/DisplayRule.aspx?Rule=41:10:04>

Waste Disposal Site

The Contractor will be required to furnish a site(s) for the disposal of construction/demolition debris generated by this project.

Construction/demolition debris may not be disposed of within the Public ROW.

The waste disposal site(s) will be managed and reclaimed in accordance with the following from the General Permit for Highway, Road, and Railway Construction/Demolition Debris Disposal Under the South Dakota Waste Management Program issued by the Department of Agriculture and Natural Resources.

The waste disposal site(s) shall not be located in a wetland, within 200 feet of surface water, or in an area that adversely affects wildlife, recreation, aesthetic value of an area, or any threatened or endangered species, as approved by the Engineer.

If the waste disposal site(s) is located such that it is within view of any ROW, the following additional requirements will apply:

Construction/demolition debris consisting of concrete, asphalt concrete, or other similar materials shall be buried in a trench completely separate from wood debris. The final cover over the construction/demolition debris shall consist of a minimum of 1 foot of soil capable of supporting vegetation. Waste disposal sites provided outside of the Public ROW shall be seeded in accordance with Natural Resources Conservation Service recommendations. The seeding recommendations may be obtained through the appropriate County NRCS Office. The Contractor shall control the access to waste disposal sites not within the Public ROW through the use of fences, gates, and placement of a sign or signs at the entrance to the site stating "No Dumping Allowed".

Concrete and asphalt concrete debris may be stockpiled within view of the ROW for a period of time not to exceed the duration of the project. Prior to project completion, the waste shall be removed from view of the ROW or buried and the waste disposal site reclaimed as noted above.

The above requirements will not apply to waste disposal sites that are covered by an individual solid waste permit as specified in SDCL 34A-6-58, SDCL 34A-6-1.13, and ARSD 74:27:10:06.

Failure to comply with the requirements stated above may result in civil penalties in accordance with South Dakota Solid Waste Law, SDCL 34A-6-1.31.

All costs associated with furnishing waste disposal site(s), disposing of waste, maintaining control of access (fence, gates, and signs), and reclamation of the waste disposal site(s) shall be incidental to the various contract items.

Historical Preservation Office Clearances

All earth disturbing activities *not designated within the plans* require review of cultural resources impacts. This work includes, but is not limited to: staging areas, borrow sites, waste disposal sites, and all material processing sites.

The Contractor will arrange and pay for a cultural resource survey, and when necessary, a cultural resource survey. The Contractor has the option to contact the state Archaeological Research Center (ARC) at 605-394-1936 or another qualified archaeologist, to obtain either a records search or a cultural resources survey. A record search might be sufficient for review; however a cultural resources survey may need to be conducted by a qualified archaeologist.

The Contractor shall provide ARC with the following: a topographical map or aerial view on which the site is clearly outlined, site dimensions, and project number. If applicable, provide evidence that the site has been previously disturbed by farming, mining, or construction activities with a landowner statement that artifacts have not been found on the site.

The Contractor will submit the records search or cultural resources survey report to SDDOT Environmental Office, 700 East Broadway Avenue, Pierre, SD 57501-2586 (605-773-3180). SDDOT will submit the information to the appropriate SHPO/THPO. Allow *30 Days* from the date this information is submitted to the Environmental Engineer for SHPO/THPO review.

If evidence for cultural resources is uncovered during project construction activities, then such activities shall cease and the Project Engineer shall be immediately notified. The Project Engineer will contact the SDDOT Environmental Engineer in order to determine an appropriate course of action.

SHPO/THPO review does not relieve the Contractor of the responsibility for obtaining any additional permits and clearances for staging areas, borrow sites, waste disposal sites, or material processing sites that affect wetlands, threatened and endangered species, or waterways. The Contractor will provide the required permits and clearances to the Project Engineer.

Grade Stakes

All lines, grade stakes, and benchmarks set by the Engineer in connection with the work herein provided for, shall be carefully preserved by the Contractor and shall not be disturbed or moved from the exact position and elevations, as set by the Engineer. Stakes that must be removed as the work progresses shall be removed only with the approval of the Engineer. The costs for staking shall be the responsibility of the Owner.

Testing & Inspection

The Owner and Engineer, and/or their representatives, shall have access at all times to all parts of the job. The Contractor shall furnish the Engineer with such facilities and materials as are necessary to make any tests and inspections deemed necessary.

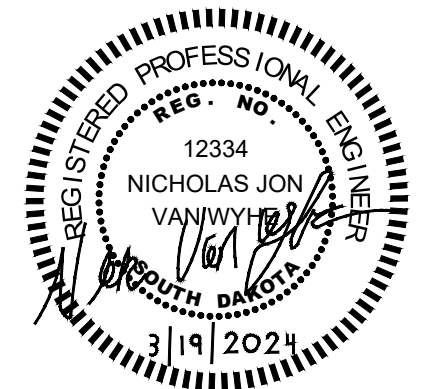

Contractor's Superintendent

The Contractor shall designate a qualified, experienced construction foreman or superintendent, who shall be present at the work site whenever any significant construction activities are being performed. This person shall be familiar with the project and equipped with plans and specifications when they are on the job site. The Contractor's designated superintendent shall be responsible for communicating all scheduling and staking needs throughout the construction process.

Staging and Parking

The Contractor is responsible for determining staging and parking areas for materials and personnel onsite. Materials, vehicles, and equipment shall not restrict use of public streets and facilities. Work shall be coordinated to avoid conflict with community events during the construction process. All costs associated with determining, securing, and safety measures required for staging and parking shall be incidental, and no separate payment will be made.

Temporary Drainage

Drainage is the Contractor's responsibility. The Contractor shall be aware of existing drainage conditions and facilities, and shall provide for drainage during construction. Damage caused by improper temporary drainage facilities shall be repaired at the Contractor's expense and to the satisfaction of the Engineer. It is expected that the contractor will be closely monitoring weather forecasts. If a rain event is anticipated, appropriate measures shall be taken to minimize flooding potential, protect construction progress, and minimize the transport of sediment from leaving the site.

Trench Dewatering

The geotechnical report is included in the project manual for review of groundwater depth. Groundwater depth will fluctuate seasonally and yearly. Dewatering as required shall be considered incidental to the installation of all underground systems and components.

Remove Tree

Trees noted for removals will be completed by the Owner prior to Work being completed.

If the trees or shrubs that are to remain within the limits of work are damaged or destroyed by the Contractor, the Contractor shall replace them with the same size and type at the Contractor's expense. Trees that are to remain shall be protected with orange construction fence or other approved method (incidental work).

Remove & Salvage Light Pole

Light poles and luminaires will be removed by Owner prior to start of project. Contractor will coordinate with Owner to confirm necessary Work has been completed to start project.

Remove Storm Sewer Pipe

In order to avoid proposed site conflicts and migration of soils, existing storm sewer pipe must be fully removed as indicated in the plans. **Abandoning in-place or burial will not be acceptable.**

PVC Storm Sewer

PVC Storm Sewer shall be installed at the location(s) indicated on the plans. PVC Storm Sewer Pipe shall conform to the latest revision of ASTM D3034, SDR 35 and shall have gasketed joints conforming to ASTM D3212 and ASTM F-477. All PVC storm piping shall be bedded to above the pipe as indicated in the plan details.

Drain Basins

All drain basins shall be Nyloplast or approved equal. The castings shall be Nyloplast (or approved equal) ductile iron frame and grates that are compatible with the drain basin and as shown in the plan details. All castings shall be capable of supporting H-20 loading. Connections from existing storm pipe to new drainage basins shall include the appropriate fitting(s). Connection is incidental to unit bid price for installation of drain basin. Install per the manufacturer's installation instructions. In-place drain basins shall be protected from siltation during construction and must have Inlet Sediment Control.

Products other than those indicated will require prior approval of the Engineer. Prior to ordering, the Contractor shall submit shop drawings for all drainage basins, which shall indicate pipe sizes, locations, material type, grate, overall height, etc. All drain basins must be

delivered to the site with one foot (1') additional height and must be cut to the appropriate height in the field. If the basins are improperly cut, the Contractor shall be responsible for the appropriate adjustments. The Contractor may want to consider a riser section for each drain basin to allow for temporary drainage during construction. The Contractor is responsible for all temporary drainage throughout the project.

HDPE Storm Sewer

HDPE Storm Sewer shall be installed at the location(s) indicated on the plans. HDPE Storm Sewer Pipe shall be dual walled with a smooth interior and annular exterior corrugations. Pipe shall be perforated to allow for underground drainage and enclosed in drainage sock. Joints shall be bell and spigot with soil-tight gaskets meeting ASTM F477. Fittings shall be from the same manufacturer as the pipe. Where indicated on the drawings, lateral connections to storm pipe shall be made with an Inserta Tee fitting for the sizes and types of pipe that are being connected. All HDPE storm pipe shall be fully bedded as indicated in the details in the Drawings.

Grading Operations

The Contractor may perform grading or surfacing work only during daylight hours unless additional hours are approved by the Owner/Owner's Representative.

Salvaged topsoil for general use as a growth medium may be obtained from the top six-inches (6") of the in-place soil horizon. As part of the salvage operation, all debris and any stones exceeding three inches (3") in any dimension shall be removed prior to stockpiling. The Salvaged Topsoil shall be stockpiled in a location chosen by the Contractor and approved by the Owner/Owner's Representative and protected in accordance with best management practices for erosion control. This may include placing High Flow Silt Fence around the perimeter of the stockpile and/or temporary seeding with an annual species such as oats or wheat. If site does not allow for space to stockpile topsoil onsite, then Contractor shall include all costs to provide a stockpile location offsite and return topsoil to allow for the minimum depth of topsoil as specified in the unit bid price.

Excavation and embankment construction shall be performed in accordance with Section 120 of the SD DOT Standard Specifications, except as modified herein. Compaction requirements shall be governed by the Specified Density Method. Excess moisture in the embankment material shall be removed by drying operations.

Following rough grading of the subgrade and completion of all underground work, the Contractor will be required to complete the Scarify & Recompact as specified herein.

Water for compaction of the subgrade shall be provided by the Contractor as necessary and used to maintain the material at or near optimum moisture content during placement and compaction operations. Water for compaction shall be incidental to the various classes of excavation.

Density shall be a minimum of 95% of the maximum dry density obtained by Standard Proctor for subgrade and utility trench material. In accordance with the geotechnical report, the moisture content of the prepared subgrade (12" depth minimum) and all trench backfill within 3 feet of the finished subgrade surface shall be maintained within a range of plus two percent (+2%) to minus two percent (-2%) of the material's optimum moisture content. Subgrade testing shall be completed by the Owner's representative following the scarification & recompaction of the subgrade and acceptance of the proof roll.

After completing subgrade shaping and compaction, and prior to placement of Non-Frost Suceptable Fill, the Contractor shall contact the Engineer to verify finished subgrade elevations are within ± 0.05ft of completed grading surfaces.

TABLE OF ESTIMATED EXCAVATION QUANTITIES				
Section	Placing Topsoil	Cut	Fill	Waste
	(CuYd)	(CuYd)	(CuYd)	(CuYd)
Pickleball Court Total Site	150	2,665	180	2,485

Estimated Shrinkage Factor Embankment = -40%

*Unclassified Excavation= Total Cut + Total Fill = 2,665 CuYd + 180 CuYd
Total Unclassified Excavation = 2,845 CuYd

*Excavation area includes a 2-ft extended perimeter of the typical post-tensioned concrete playing surface section from edge of concrete.

**Scarify & Recompact = 700 CuYd

**Scarify and Recompact area includes a 2-ft extended perimeter of the typical post-tensioned concrete playing surface section from edge of concrete.

Waste

The Contractor shall utilize the most favorable material found in the excavation for reuse as subgrade fill. The use of onsite material will require moisture conditioning as noted herein and in the geotechnical report. Unit bid prices for the various classes of excavation shall include moisture conditioning and recompaction for onsite use.

All waste earthen material shall be stockpiled on site. The Owner will retain waste earthen material and will be hauled off site by Owner. All costs to load and assist Owner in waste removal from the site shall be incidental. Calculated quantities do not include any excess or shortages in subgrade material as a result of the installation or removal of underground utilities. The plan quantities for earthwork items will be the basis of payment, unless additional work is approved.

Note: Plan Sheet Includes Revised Layout and Quantities.

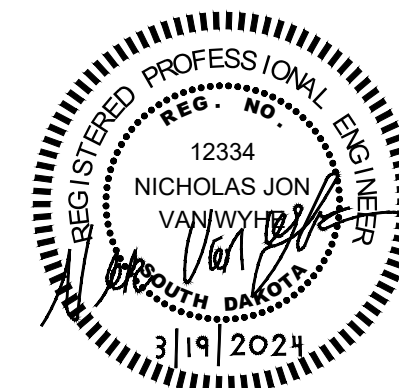

Scarify & Recompact (1' minimum)

As shown in the typical section(s), the earthen subgrade shall be scarified, moisture conditioned, and recompact to a depth of 1' (minimum) below the finished earthen subgrade surface. The scarified material or other suitable material, as directed by the Engineer, shall be moisture conditioned to the specified range (+2% to -2% of optimum moisture content), and compacted to a minimum density of 95% Standard Proctor density. The final surface shall be proof rolled with a loaded tandem truck with a minimum 10-ton load, as stated in the Grading Operations. All proof rolling will be performed in the presence of the Owner's Representative. Soft or yielding areas will be repaired at the Contractors expense prior to any placement of Non-Frost Susceptible Fill.

Non-Frost Susceptible Fill

The Contractor shall be required to use a Non-Frost Susceptible Fill material, as directed by the Owner or Engineer. The fill material, unless otherwise directed, shall conform to the following sieve analysis: Percentage by weight

Sieve	Percent Passing
No. 40	<40%
No. 200	<5%

Note: Material shall be required to have a 1-inch maximum particle size

The fill section shall consist of a 4-ft thickness, with a 2-ft extended perimeter around the post-tensioned concrete pavement extents. All lifts must be placed at a 1-ft maximum thickness. Moisture content of Non-Frost Susceptible Fill shall be maintained at a level that will be conducive for vibratory compaction. The material shall be compacted to a minimum density of 95% standard Proctor density. The final surface shall be within ±0.05ft of finished grade and be smooth, free from waves and irregularities. Soft or yielding areas will be repaired at the Contractors expense prior to any placement of aggregate base course. Material submittal and Engineer approval prior to installation is required. The Contractor shall supply weight tickets. No payment will be made for materials without a ticket.

Aggregate Base Course

Aggregate Base Course shall comply with Sections 260 and 882 of the SD DOT Standard Specifications, unless modified herein. The Contractor shall supply weight tickets in accordance to the specifications. No payment will be made for materials without a ticket.

Aggregate Base Course shall be placed to the dimensions and thickness indicated on the Typical Sections. Aggregate Base Course shall be placed over prepared and approved subgrade and Non-Frost Susceptible Fill as indicated.

Aggregate Base Course shall be from a Contractor furnished source. Base Course density shall be a minimum of 97% of the maximum dry density obtained by Standard Proctor. Each layer shall be compacted to the specified density before the next lift is placed and shall be rolled until a uniform, stable surface is obtained.

The final compaction of the top surface of the granular materials shall embed as many loose stones as possible. The finished surface shall be smooth, free from waves, and within ±0.05% of the typical section cross slope when measured with a straight edge, stringline, or other suitable equipment.

Water for compaction of the base course shall be provided by the Contractor, if necessary and used to maintain the material at or near optimum moisture content during the compaction process. Water shall be considered incidental to the per ton unit bid price for Aggregate Base Course.

Base Course shall conform with Section 882 of the SD DOT Standard Specifications in addition to that specified herein.

Granular material of which a minimum of 30% of the particles retained on the No. 4 sieve shall contain one or more fractured faces.

The fraction passing the No. 200 sieve shall not be greater than 2/3 of the fraction passing the No. 40 sieve. In no case shall the upper limit specified for the No. 200 sieve be exceeded.

Base Course shall conform to standard gradation shown below.

Sieve	Percent Passing
1"	100
3/4"	80 - 100
1/2"	68 - 91
No. 4	46 - 70
No. 8	34 - 58
No. 40	13 - 35
No. 200	3.0 - 12.0
Liquid Limit , max	25
Plasticity Index	1 - 6
LA Abra. Loss, max	40
Crushed Particles, min	30% 1-CF

Woven Geotextile Fabric

Woven Geotextile Fabric shall be installed at the location(s) indicated in the typical section(s) and on the plans. Storage and placement of Woven Geotextile Fabric shall be in accordance with the manufacturer's recommendations. Products other than those indicated on the plans will require prior approval of the Engineer. All Woven Geotextile Fabric shall be Mirafi HP 270 or an approved equal. The square yard unit bid price shall include all labor, equipment and material to furnish and install the geotextile fabric on the prepared Non-Frost Fill surface. Overlap of the geotextile fabric shall be per manufacturer's recommendations and will be incidental to unit bid price.

Post-Tensioned Concrete Pavement

The Contractor will be required to provide a design submittal for the Post-Tensioned Concrete Pavement that is prepared by a Professional Engineer registered in the State of South Dakota. Sealed calculations of the design along with a proposed post-tensioned layout plan will be required. If the proposed design submittal includes jointing of Post-Tensioned Concrete Pavement, the design submittal shall include a jointing layout plan. All designs shall conform to the standards of outdoor post-tensioned concrete playing surfaces by the American Sports Builders Association (ASBA) and the Post-Tensioning Institute (PTI). The Contractor will be required to provide documentation of at minimum three(3) previous projects completed in the last five(5) years. The Contractor will be required to have personnel on site during construction of the Post-Tensioned Concrete Pavement that are certified for installation of post-tensioned surfaces.

All Work associated with Post-Tensioning Concrete Pavement shall be completed in accordance with the Manufacturer's Recommendations and in accordance with the Contractor's design submittal. No part of the Work is to be subcontracted to provide continuity and one source responsibility for the integrity of the post-tensioned pavement.

Prior to pouring Post-Tensioned Concrete Pavement, all fence posts, net posts or sleeves, and center anchors that have independent foundations or footings, should be installed and wrapped with 1/2" preformed foam expansion material. Application of joint sealant shall be required after completion of the concrete pavement. 1/2" preformed foam expansion joint material shall be installed at locations shown in the plans and/or specifications and as directed by the Engineer. Expansion material will be considered incidental to the unit price of concrete surfacing.

All concrete for the Post-Tensioned Concrete Pavement shall be Class M6 Concrete and conform to the SD DOT Standard Specifications, Section 462. Concrete shall meet the minimum specified concrete compressive strength of 4,000 psi at 28 days. All coarse aggregates shall be crushed ledge rock.

Forming of Post-Tensioned Concrete Pavement shall be within plus or minus one-quarter inch (± 1/4") of finished grades indicated on drawings and be securely staked to prevent settlement or movement during placement of concrete. Forms shall remain until concrete has cured fully as indicated per specifications herein.

The Contractor will be required to install two (2) layers of 6 mil polyethylene sheeting as indicated on the typical section for the Post-Tensioned Concrete Pavement. Polyethylene sheeting shall be overlapped at joints and taped. Care should be taken to avoid punctures to polyethylene sheeting during installation of the post-tensioning tendons and pouring of the concrete. The Contractor shall place the polyurethane sheeting on a smooth 4-inch (4") layer of compacted aggregate base course. All costs associated with labor, materials and equipment for placing the polyethylene sheeting shall be incidental to the bid item for Post-Tensioned Concrete Pavement.

Concrete shall be vibrated in-place prior to screeding operations. All joints shall be finished with an approved edging tool. Begin screeding and floating as soon as the water sheen has disappeared. Immediately after float finish, the surface shall be broomed to a medium finish to allow application of acrylic surfacing products and remove finishing tool marks. The finished surface shall not receive any curing compounds. The Post-Tensioned Concrete Pavement shall be moist cured for approximately seven (7) days following the initial pour of the slab. The surface shall be covered with burlap or polyethylene sheeting to keep surface in moist condition. Additional curing of Post-Tensioned Concrete Pavement after initial 7-day cure time shall be at minimum 28-days prior to any further Work performed on the concrete surface. Work shall be planned accordingly to avoid project delays during the cure time.

The finished pavement shall be inspected for irregularities and evenness. Non-compliant pavement shall include irregularities that have greater than 1/8" difference when measured with an 18-inch straight edge, or greater than 1/4" difference when measured with a 10-foot straight edge at a 1% slope. The constructed slope shall be at minimum 0.83% and maximum 1.0%. Failure to comply with slope requirements may result in price adjustment or rejection of the concrete. The Contractor will be required to address any non-compliant surfaces by corrective measures approved for the surfacing materials manufacturer and certified by the Engineer or Owner Representatives.

Post-Tensioning strands shall conform to the "PTI Guide Specifications for Post-tensioning Materials." Tensioning strands shall consist of one-half inch (1/2") diameter, 7-wire, stress relieved strands, having a guaranteed ultimate tensile strength of 270,000 PSI (270 ksi). Strands shall conform to ASTM-416. Cables shall be fabricated to proper length for each slab, coated with a permanent rust preventative lubricant and encased in slip-age sheathing and shall be repaired with tape prior to concrete placement as necessary. A maximum of six inches (6") of exposed strands is permitted at the dead-end anchor. The cables shall be anchored approximately 4" down from the surface of the slab. Two #4 reinforcement bars lay continuously longitudinally around the court beam directly inside the cable anchor on top of the cables. Overlapping should be a minimum of 30 diameters.

Post-Tensioning strands shall be placed on chairs with the chairs having a maximum spacing of four feet and six inches (4'-6"). Where strands overlap, cables shall be loosely tied two inches (2") high to prevent vertical and horizontal movement during concrete placement. Strands shall be placed per the design submittal.

Post-Tensioning strands shall be placed to avoid fence posts, net posts or sleeves, and center anchors that have independent foundations or footings. There shall be a minimum of a 6-inch clear zone between proposed tension strands and in-place footings or blocked out areas. Once the Post-Tensioned Concrete Pavement has been constructed, partial tensioning of tendons shall be completed at 18-24 hours after concrete pour to prevent initial shrinkage cracks. Cable ends shall be cut off and cone holes grouted flush with edge of slab once tendons are fully tensioned and concrete has fully cured. Grout shall be non-shrink grout. Tensioning of strands shall follow the Contractor Design Submittal.

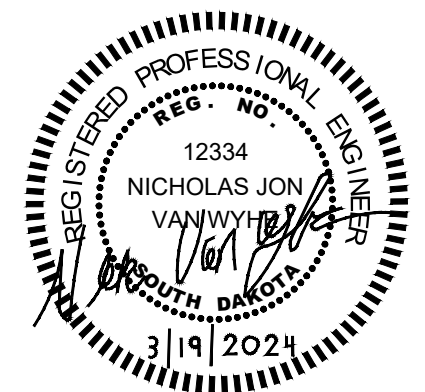

Pickleball Court - Netting System

The Contractor will be required to include court netting, post, and footing design as part of the design submittal for the Post-Tensioned Playing Pavement. Netting, posts, and post footings shall be installed per specified plans by design submittal Engineer.

The Netting System for pickleball courts shall be designed and installed per ASBA and USAPA required dimensions of standard pickleball courts.

Netting material shall be polyethylene mesh that does not allow a pickleball through. The width of netting shall be thirty inches (30") allowing a six-inch (6") gap between playing surface and bottom of mesh netting.

Clean Post-Tensioned Concrete Pavement

The Contractor shall be required to clean any dirt, sediment, mud or other deleterious materials from the concrete pavement. After cleaning the surface no equipment or construction traffic will be allowed over the surface. The Contractor shall plan work accordingly. All costs associated with labor, materials, and equipment for cleaning of the concrete pavement shall be incidental to the bid item for Post-Tensioned Concrete Pavement.

5" Concrete Sidewalk

Concrete sidewalk shall be constructed as shown on the plans and in accordance with Section 651 of the SDDOT specifications except that coarse aggregate for concrete shall be crushed ledge rock. Joints on the sidewalk shall be tooled at a typical 5-ft spacing transverse to the sidewalk. On sidewalk directly adjacent to Post-Tensioned Concrete Pavement, provide preformed expansion joint filler that is 1/2" in width.

All concrete sidewalk shall be five (5") inches thick unless specified otherwise, and a minimum five (5") inches of base course shall be placed beneath the sidewalk. The forms for placement of the concrete sidewalk shall be no less than 5" in height.

Sidewalk shall meet Americans with Disabilities Act (ADA) Requirements. Maximum cross slope shall be 2%, and maximum running slope shall be 5%. The maximum ramp slope shall be 8.33%. Notify the Engineer if discrepancies are observed.

Aggregate Base Course placed under the sidewalk will be paid under the Aggregate Base Course bid item.

Concrete Curing

This Post-Tensioned Concrete Pavement shall not have any curing compounds applied to the completed surface. The curing of Post-Tensioned Concrete Pavement shall be in accordance to specifications previously stated herein.

All concrete sidewalk shall be cured in accordance with section 380.3.M.2 of the 2015 SDDOT Standard Specifications, except as modified in this note. All concrete sidewalk shall be cured with a white pigmented linseed oil base emulsion compound when cured using the Impervious Membrane Method. Curing compound material shall be in accordance with section 821.1.C.

Apply liquid curing compound in a fine spray to form a continuous, uniform solid white opaque coverage (equal to a white sheet of typing paper) on the horizontal surface of sidewalk immediately after surface moisture has disappeared, but no later than 30 minutes after finishing. Apply the curing compound in 1 equal application to ensure a uniform coverage. With the approval of the Engineer, the timing of cure application may be adjusted due to varying weather conditions and concrete mix properties to ensure acceptable macrotexture is achieved. Failure to comply with the provisions may result in a price adjustment or rejection of the concrete.

Alkali Silica Reactivity

Fine aggregate with a 14 day expansion value below 0.250 shall require Type II cement with a fly ash content of 20 to 25% in the concrete mix. If the expansion value is 0.250 or greater, the mix shall require Type II cement with fly ash content of 25%. An expansion value of 0.400 or greater may not be used.

Below is a list of known fine aggregate sources and the average corresponding 14 day expansion values. These values are as indicated in SDDOT documents and may not include all available sources. The Contractor must submit and provide documentation if requested of the most recent testing completed on the fine aggregate source.

Source	Location	Expansion Value
Bachman	Winner, SD	0.335*
Bitterman	Delmont, SD	0.316*
Concrete Materials	Corson, SD	0.146
Croell	Hot Springs, SD	0.089
Croell	Wasta, SD	0.212
Emme Sand & Gravel	Onel, NE	0.217
Fisher S&G - Mickelson Pit	E of Nisland, SD	0.129
Fisher S&G - Vallery Pit	Nisland, SD	0.110
Fisher S&G	Rapid City, SD	0.092
Fisher S&G	Spearfish, SD	0.053
Fisher S&G	Wasta, SD	0.159
Fuchs	Pickstown, SD	0.275*
Higman	Hudson, SD	0.187
Jensen	Herried, SD	0.276*
L.G. Everist	Akron, IA	0.257*
L.G. Everist	Brookings, SD	0.267*
L.G. Everist	Hawarden, IA	0.166
L.G. Everist	Summit, SD	0.178
Morris	Blunt, SD	0.192
Morris - Richards Pit	Onida, SD	0.188
Morris - Shawn's Pit	E of Sturgis, SD	0.186
Myrl & Roys - Ode Pit	E Sioux Falls, SD	0.214
Myrl & Roys - Nelson Pit	NE Sioux Falls, SD	0.156
Northern Concrete Agg.	Rauville, SD	0.113
Northern Concrete Agg.	Luverne, MN	0.133
Opperman - Gunvordahl Pit	Burke, SD	0.363*
Opperman - Cahoy Pit	Herrick, SD	0.307*
Opperman - Jones Pit	Burke, SD	0.321*
Opperman - Randall Pit	Pickstown, SD	0.239
Pete Lien & Sons	Creston, SD	0.158
Pete Lien & Sons	Orla, SD	0.129
Pete Lien & Sons	Wasta, SD	0.192
Thorpe Pit	Britton, SD	0.098
Wagner Building Supplies	Pickstown (Wagner), SD	0.241
Winter Brothers - Whitehead Pit	Brookings, SD	0.197

* These sources will require Type II cement with a fly ash content of 25% in the concrete mix.

The running average of the last three known expansion test results or less will be used in determining acceptability of source and the required Type of cement. Additional testing, may be performed at the Contractor's expense.

The values listed in the table are intended for use in bidding only.

The Contractor is responsible for providing a mix design and delivering a product that meets the specifications.

Placing Topsoil

Topsoil shall be placed in accordance with Section 230 of the SD DOT Standard Specifications to a minimum depth of eight inches (8") on all areas to be seeded. The Contractor shall complete excavation and removal of materials to allow for consistent, clean, uncontaminated topsoil to be placed to the depth indicated. The topsoil material shall be substantially free of rocks, gravel, concrete chunks, wood or other foreign debris. Prior to seeding, topsoil preparation shall be completed in accordance with Section 730.3.D. Topsoil shall be placed 1/2" to 1" below the adjacent sidewalk or post-tensioned concrete surface, and be graded to provide a smooth even surface. Dirt ridges shall be smoothed to not interfere with future mowing operations.

Drills

In addition to the drills specified in Section 730 of the Standard Specifications, other types of drills including no-till drills will be allowed as long as they have baffles, partitions, agitators, or augers which keep the seed distributed throughout the seed box and the seed is planted at a depth of 1/4" to 1/2" .

Permanent Seeding

Seed all areas within the project that were disturbed during construction operations. Work shall be in accordance with Section 730 of the SDDOT Standard Specifications.

All permanent seed shall be planted in the topsoil at a depth of 1/4" to 1/2". Seeding must be completed using a press drill meeting SDDOT Standard Specifications. Broadcasting of seed may only be completed in areas where a press drill cannot be operated and only with prior written approval from the Engineer. All seed broadcast must be raked or dragged in (incorporated) within the top 1/4" to 1/2" of topsoil. No exceptions.

Prior to permanent seeding, the Contractor shall till all areas to be seeded to a depth of approximately 3 inches. Seed preparation shall be completed in accordance with the SDDOT Standard Specifications. Seeding shall not be performed on contaminated topsoil. All materials, labor and equipment to prepare the seedbed and provide permanent seeding shall be included in the unit bid price(s).

The seed mix shall consist of the following:

Grass Species	Variety	Pure Live Seed (PLS) (Lbs/1000 SqFt)
Kentucky Bluegrass	Avalanche, Appalachian, Wildhorse, Blue Bonnet, Action	1.4
Perennial Ryegrass	Turf Type Varieties	1.4
Creeping Red Fescue	Epic, Boreal, Chantilly	1.4
Chewings Fescue	Ambrose, K2, Zodiac, Shadow III	1.4
Alkali Grass	Fults, Fults II, Quill, Salty	1.4
Total		7

Total = 0.3 acres = 13.202(1000sqft) x 7 lbs/(1000sqft) = 95 lbs

Note: Plan Sheet Includes Revised Layout and Quantities.

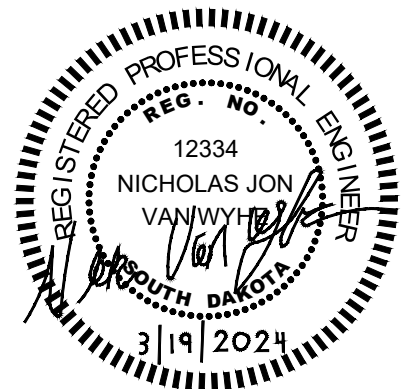

Mycorrhizal Inoculum

Mycorrhizal Inoculum shall consist of mycorrhizal fungi spores and mycorrhizal fungi-infected root fragments in a solid carrier. The carrier may include organic materials, calcinated clay, or other materials consistent with application and good plant growth. The supplier shall provide certification of the fungal species claimed and the live propagule count. The inoculum shall include the following fungal species:

Glomus intraradices	25%
Glomus aggregatu	25%
Glomus mosseae	25%
Glomus etunicatum	25%

All seed shall be inoculated by the seed supplier with a minimum of 20,000 live propagules of mycorrhizal fungi per 1,000 square feet. All costs of inoculating the seed shall be incidental to the contract unit price per pound for the corresponding permanent seed mixture.

Fertilizing

The Contractor shall apply an all-natural slow release fertilizer prior to seeding or placing sod. The all-natural fertilizer shall have a minimum guaranteed analysis of 4-6-4 and be USDA Certified BioBased. The all-natural fertilizer shall be applied to all areas designated for seeding/sodding and according to the manufacturer's application recommendations. The application rate of fertilizer shall be 12.5 pounds per 1,000 square feet.

The all-natural slow release fertilizer shall be from the list below or an approved equal:

Product	Manufacturer
Sustane	Sustane Corporate Headquarters Cannon Falls, Minnesota Phone: 1-800-352-9245 www.sustane.com
Perfect Blend	Perfect Blend, LLC Bellevue, WA Phone: 1-866-456-8890 www.perfect-blend.com

Fiber Mulching

Fiber mulch shall be applied in a separate operation following permanent seeding. Fiber mulching shall be in accordance with Section 732 of the SDDOT Standard Specifications, except as modified herein.

Fiber mulch shall be premixed with a guar gum tackifier or synthetic tackifier. The products shown below include 3% guar gum or synthetic tackifier. An additional 2% of tackifier shall be added to the fiber mulch. If the product selected has guar gum tackifier included, then the additional 2% tackifier shall be guar gum. If the product selected has synthetic tackifier included, then the additional 2% tackifier shall be synthetic. The additional 2% of tackifier shall be applied at the rate of 40 pounds per acre. Fiber mulch shall be applied at the rate of 2000 pounds per acre.

The Contractor shall allow the fiber mulch to cure a minimum of 18 hours prior to watering or any storm event to ensure proper cohesion between the soil and fiber particles.

All costs for the additional tackifier added to the fiber mulch including labor, equipment, and materials shall be incidental to the contract unit price per Ton for "Fiber Mulching".

The fiber mulch provided shall be from the SD DOT approved product list. The approved product list for fiber mulch may be viewed at the following internet site:

<http://sddot.com/business/certification/products/Default.aspx?Fertilizing>

Warranty - Fence

The Contractor shall supply warranty, separate from the manufacturer, of one year. The Warranty shall include labor and materials to perform any repairs during the first year of the installation as requested by the owner.

Manufacturer shall supply a 15 year written warranty for all fence components with the warranty to begin at final acceptance of the project. Warranty shall cover all fence components, including coatings and accessories for chipping, fading, and any other manufacturer defects.

Chain-Link Fabric

Chain-Link Fabric and accessories shall be supplied by qualified manufacturers having a minimum of five years experience manufacturing galvanized coated chain link fencing. Chain Link Fabric shall be made of steel wire helically wound and interwoven in such a manner as to provide a continuous mesh without knots or ties except in the form of knuckling the ends of the wire to form the selvage of the fabric. Selvage of fabric shall be knuckled both top and bottom. Fabric height shall be as indicated on the plan. Mesh shall be a minimum of nine (9) gauge (0.148" in diameter) prior to coating with 2" mesh. Fabric shall be installed on the playing court side of fence.

Coated Wire shall comply with ASTM A 392 - 1.2 oz/sf. [Wire Spec-A817-83, Class 1] for Zinc-Coated Chain Link Fence Fabric

Steel Fence Framing

Steel pipe - Type I: ASTM F 1083, standard weight schedule 40; minimum yield strength of 25,000 psi (170 MPa); sizes as indicated. Hot-dipped galvanized with minimum average 1.8 oz/ft2 (550 g/m2) of coated surface area.

End, Corner, and Gate Posts shall be minimum 2 7/8" OD (0.203" Wall Thickness, 5.79 lb/ft). Line Posts shall be minimum 2 3/8" OD (0.154" Wall thickness, 3.65 lb/ft) and horizontal rails and braces shall be minimum 1 5/8" OD (0.140" Wall thickness, 2.27 lb/ft).

Chain link fence accessories:

- A. [ASTM F 626] Provide items required to complete fence system. Galvanize each ferrous metal item and finish to match framing with other coatings as specified elsewhere.
- B. Post caps: Formed steel, cast malleable iron, or aluminum alloy weather tight closure cap for tubular posts. Provide one cap for each post with style chosen by the Owner/Engineer. Caps to match posts in color and be designed to fit the post.
- C. Top rail and brace rail ends: Pressed steel per ASTM F626, for connection of rail and brace to terminal posts.
- D. 8-ft fence gate frames shall have a mid-rail installed on frame.
- E. Top rail sleeves: 7" (178 mm) expansion sleeve with spring, allowing for expansion and contraction of top rail.
- F. Wire ties: 9 gauge [0.148" (3.76 mm)] galvanized steel wire for attachment of fabric to line posts. Double wrap 13 gauge [0.092" (2.324 mm)] for rails and braces.
- G. Brace and tension (stretcher bar) bands: Pressed steel. At square post provide tension bar clips.
- H. Tension (stretcher) bars: One piece lengths equal to 2 inches (50 mm) less than full height of fabric with a minimum cross-section of 3/16" x 3/4" (4.76 mm x 19 mm).
- I. Tension wire: Galvanized coated steel wire, 7 gauge, [0.177" (4.5 mm)] diameter wire with tensile strength of 75,000 psi (517 MPA).
- J. Truss rods & tightener: Steel rods with minimum diameter of 3/8" (7.9 mm). Capable of withstanding a minimum tension of 2,000 lbs.
- K. Nuts and bolts are galvanized.

Fence Post - Footings

Footings for posts shall be the minimum size as indicated in the details. Concrete for footings shall conform to Class M6, Section 462 of the SD DOT Standard Specifications for Roads and Bridges, 2015 Edition. To eliminate the danger of frost heaving the post, concrete in the crown top of the footing shall not be larger than the concrete in the lower part of the footing. Footings shall be not less than 12" in diameter and not less than 3'-6" in depth. Footing holes shall be drilled in firm undisturbed or compacted soil. Excavate deeper as required for adequate support in soft and loose soil, and for posts with heavy lateral loads. Place concrete around posts in a continuous pour. Trowel finish around post. Slope to direct water away from posts.

Fence Construction

Install 4' and 8' chain-link fence in accordance with ASTM F 567 and manufacturer's instructions. Install End and Corner post at each fence termination and change in horizontal or vertical direction of 30° or more in the fence alignment.

Space line posts uniformly at not more than 8' on center. In determining post spacing, measurement will be made parallel to the slope of the ground. Install line posts vertical and aligned as indicated in the plan.

Horizontal Bracing shall be installed at mid-height for fences 8' high and over on each side of an end or corner post. Horizontal Bracing shall be firmly attached with fittings designed for this application. Install diagonal truss rods at these points and adjust with turnbuckle to ensure posts remain plumb.

Install bottom rails between posts with fittings and accessories where indicated.

Install fabric on the inside of the 8' fence and on the playing surface side of the 4' fence, and attach so that fabric remains in tension after pulling force. Leave approximately 2" (50 mm) between finish grade and bottom selvage. Attach fabric with 9 gauge wire ties to line posts at 15" (381 mm) on center and to rails, braces, and tension wire at 24" (600 mm) on center. If fence fabric must be spliced, it shall be joined by weaving a single strand into each of the rolls to form a continuous mesh.

Install Tension (stretcher) bars at corners and ends and as required to maintain tension in fabric. Thread tension bar through fabric and attach to terminal posts with bands or clips spaced maximum of 15" (381 mm) on center.

Tension wire: Provide tension wire at bottom of fabric for security fencing or where indicated on the plan. Install tension wire before stretching fabric and attach to each post with ties. Secure tension wire to fabric with 12 ½ gauge galvanized [0.0985" (2.502 mm)] hog rings 24" (610 mm) OC. Bend ends of wire to minimize hazard to persons and clothing.

Fasteners: Install nuts on side of fence opposite fabric side for added security or to the outside of the field of play for safety.

Polyvinyl Chloride Fence Coating
Fence materials and components necessary to complete Work shall have a polyvinyl chloride coating matching the standard color in ASTM F934 for the color Black. All fencing materials shall be submitted to the Engineer for review and approval of material coatings.

Note: Plan Sheet Includes Revised Layout and Quantities.

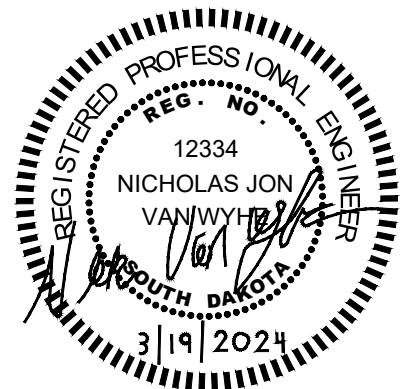

High Flow Silt Fence

The high flow silt fence fabric provided shall be from the approved product list. The approved product list for high flow silt fence may be viewed at the following internet site:

<http://apps.sd.gov/HC60ApprovedProducts/main.aspx>

High flow silt fence shall be placed at the locations noted in the plans and at locations that will minimize siltation of adjacent drainage areas as determined by the Engineer during construction. Refer to Standard Plate 734.05 for details.

Mucking Silt Fence

Mucking silt fence shall consist of removing muck trapped by the silt fence and spreading the material evenly over the adjacent area to conform to the existing grade. Mucking silt fence shall be incidental to the cost for silt fence and is considered to be routine maintenance.

Remove Silt Fence

Silt fence shall be removed when vegetation is established. Some or all of the silt fence may be left on the project until vegetation is established. Removal of silt fence shall be incidental to the High Flow Silt Fence bid item.

Concrete Washout Facility(CWF)

The concrete washout facility will include removal of concrete debris and restoration. See details for installation requirements. Concrete trucks will be required to washout in the designated facility only. Unless written approval is attained by the Owner / Engineer, only one CWF will be installed with this project.

Sediment Control At Inlets

Sediment control shall be maintained at existing and new storm sewer inlets throughout construction. See SD DOT Standard Plates 734.10 and 734.11. The unit bid price per each will include furnishing and installing, maintaining, removing, and resetting the sediment control in accordance with the Standard Specifications and Standard Plates.

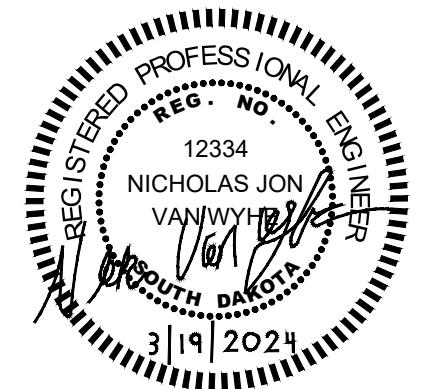

P:\Brookings\Projects\City of Brookings\2023_055 Brookings - Pickleball Courts\Design\Final Design\Alternate Layout\Increased Court Area\Notes_Final.dwg, Notes (6), 3/19/2024, 11:16 AM, Cole Burgard

SPECIFICATIONS FOR POST-TENSIONED CONCRETE SURFACING

1.1 SCOPE

Post-Tensioned Concrete Surfacing will be completed by a Surfacing Contractor and includes all labor, materials and equipment to furnish and install an acrylic based surfacing product, color coat, and associated striping. Areas to be surfaced include the Post-Tensioned Concrete Playing Surface.

The scope of the work includes the following as specified herein:

- A. Clean newly installed concrete base by air sweeper or power washing.
- B. Flooding of court to identify ponding areas and corrective measures to adjust areas deemed necessary.
- C. Application of two (2) acrylic filler coats.
- D. Application of two (2) color finish coats that include playing surface striping and markings. Markings shall adhere to American Sports Builders Association(ASBA) requirements for standard pickleball courts .
- E. All payment will be on the Lump Sum basis per the Bid Form in the Project Documents.

1.1 SUPERVISION

Surfacing contractors shall have a qualified supervisor on the job site at all times during the application of the court surfacing and to coordinate with other contractors to provide proper installation as per specifications herein and the manufacturers recommendations.

1.2 SUBMITTALS

The bidder must: provide written maintenance information to the Owner including repair methods, availability of repair materials and costs; provide a color-coded schedule of markings; provide a certification of court dimensions in accordance with the specifications (to be provided to the Owner at the time of completion); and provide company references, history and the number of years doing business. Submittals must include the following standard specifications of surfacing system to be proposed as per specifications herein, and manufacturer's certification of materials shall be provided.

1.3 AUTHORIZED INSTALLERS AND BIDDERS

- A. The court surfacing shall be completely furnished and installed by an authorized installer of the playing surface material manufacturer and shall provide documentation of such.
- B. To be consistent with the warrantee period, the installer must provide documentation of at minimum three(3) previous projects completed in the last five(5) years.

1.4 DELIVERY, STORAGE, AND HANDLING

- A. Deliver materials in the manufacturer's original, unopened containers, clearly labeled.
- B. Store and handle materials in accordance with manufacturer's instructions.
- C. Keep materials out of direct sunlight, freezing conditions, and sealed in the original unopened containers until application.
- D. Retain manufacturer batch codes on each container and application dates, for warranty purposes.

1.5 WARRANTY

Prior to final payment, the Contractor shall provide written documentation that guarantees the work against defective materials or faulty workmanship for the period of one (1) year, and that the colored surface will not wear through for a period of two (2) years from the date of completion.

1.6 COURT SURFACING PRODUCTS

- A. Contractor shall install textured acrylic color surfacing which contains rounded, non-aggressive silica sand for the pickleball court main court and court perimeter area per manufacture's specifications.
- B. All surface coatings shall be supplied by a single manufacturer.
 - 1. Acrylic filler coat shall be applied in two(2) layers.
 - 2. Color Coat shall be applied in two(2) layers.
- C. Court Markings shall be applied at a minimum of one(1) time.
- D. Contractor shall submit current material product data sheets, manufacturer specifications for components, color chart, and warranty documentation for Owner's/Owner's Representatives prior to ordering.

1.7 SURFACE PREPARATION

- A. Complete surface preparation in accordance with the manufacturer's recommendations for preparation, unless more stringent requirements are specified herein.
- B. The concrete base must cure in accordance with the manufacturer's recommendations before application of the court surfacing. Upon request, the Owner/Owner's Representative shall provide the date in which the concrete base was placed.
- C. The Contractor shall clean and remove all construction debris from the surfaces to receive the court surfacing products. The Contractor shall sweep or power blow the concrete base to remove any dust, dirt, oil, grease and loose materials. The Contractor shall pressure wash the concrete base as needed to remove deleterious materials.
- D. The new concrete shall be flooded with water and inspected by the Contractor for any conditions that would be detrimental to a successful installation of the new pickleball court surfacing. Any such condition shall be brought to the attention of the Owner/Owner's Representative. The Post-Tensioned Concrete Surface contractor shall repair any such deficiency within the scope of court installation. These repairs need to be made in accordance with the recommendations of the manufacturer of the court surfacing. Any costs associated with surface repairs shall be considered incidental to Post-Tensioned Concrete Surface bid item.
- E. The court surface shall be dry prior to applying the acrylic base layers. The installer must strictly follow the manufacturer's recommendations for surface temperature and relative humidity.

1.8 INSTALLATION

- A. Do not apply concrete pickleball court surfacing when air or surface temperatures are below or above manufacturer recommended temperatures.
- B. Do not apply concrete pickleball court surfacing when surface is wet, or rain is expected during application or within 24 hours after application.
- C. Apply concrete pickleball court surfacing in accordance with manufacturer's instructions at the locations indicated on the Drawings.
- D. Mix materials in accordance with manufacturer's instructions.
- E. Apply surfacing products with approved materials in accordance with manufacturer's instructions.
- F. Application of at minimum 2 acrylic filler coats shall be required on prepared surfaces in accordance with manufacturer's instructions.
- G. Application of at minimum 2 color coats shall be required on prepared surfaces in accordance with manufacturer's instructions.
- H. Allow material drying times in accordance with manufacturer's instructions before applying other materials or opening completed surface to foot traffic.

1.9 MARKING AND STRIPING

- A. Experienced personnel specializing in pickleball court striping shall accomplish all striping in accordance with USAPA Rules of Pickleball.
- B. The Contractor shall verify with the Owner's representative for exact locations, size, shape and color of the lines and markings before proceeding with markings and striping.
- C. Measurement shall be made with a steel tape in engineering scale that will read directly to 0.01 foot.
- D. The acrylic based paint shall be the color white, and lines shall have clear definition. Ragged lines will not be accepted.

1.10 LIMITATIONS

- A. Apply the surfacing materials only during favorable weather conditions. Work is to progress only when adequate curing can be guaranteed by the installer.
- B. During surface installation and striping, all sprinkler systems must be shut off or controlled so that no water falls on the track or event surfaces.
- C. All materials will be installed in strict compliance with the manufacturer's recommendations.
- D. During setup, installation and striping, it is the responsibility of the Contractor to have the entire pickleball court area and other pertinent areas around the project site closed and secured of all activities 24 hours prior to the curing and completion of surfacing activities.
- E. The right is reserved, as the interest of the Owner may require, to reject any and all bids, to waive any informality in bids received, and to accept or reject any bid unless such bid is qualified by specific limitation in the Owner's sole absolute discretion.

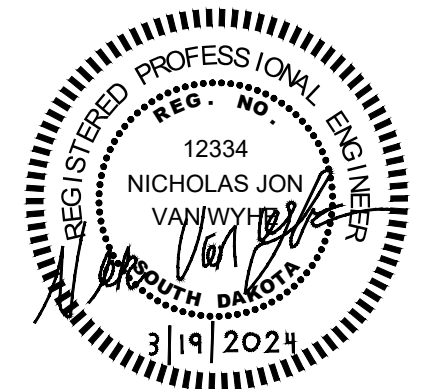

P:\Brookings\Projects\City of Brookings\2023_055 Brookings - Pickleball Courts\Design\Final Design\Final Design\Alternate Layout\Increased Court Area\Notes (7).3/19/2024 11:16 AM Cole Bunganidin

Existing Conditions, Removals and Erosion Control

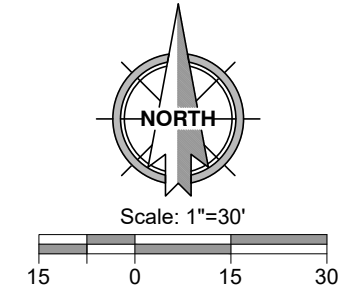

Removal Key

- ① Tree Removed by Owner
- ② Luminaire Pole Removed by Owner

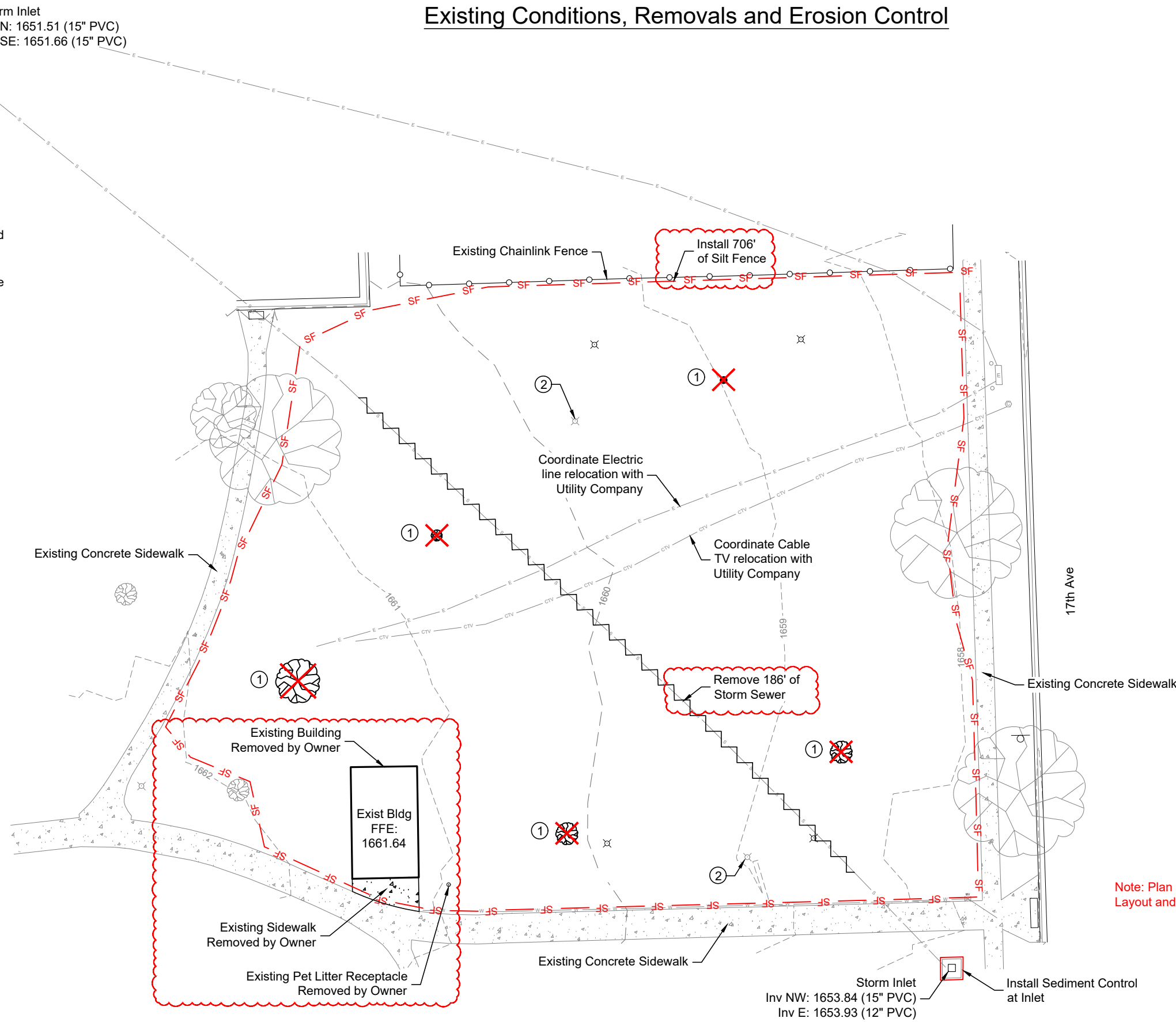

SITE LEGEND

- W — W — Water Line
- S — S — Storm Sewer Line
- E — E — Electric Line
- CTV — CTV — Telephone Line
- ⊕ Water Valve
- ⊞ Elect Transformer
- ⊙ Light Pole
- ⊙ Cable Box
- ⊙ Deciduous Tree
- ~ Storm Sewer Removal
- SF — Silt Fence
- Sediment Control at Inlets

PARTIAL TABLE OF EST. QUANTITIES

DESCRIPTION	UNIT	QUANTITY
Remove Storm Sewer Pipe	LF	186
Concrete Washout Area	EA	1
Silt Fence	LF	707
Inlet Sediment Control Device	EA	1

Note: Plan Sheet Includes Revised Layout and Quantities.

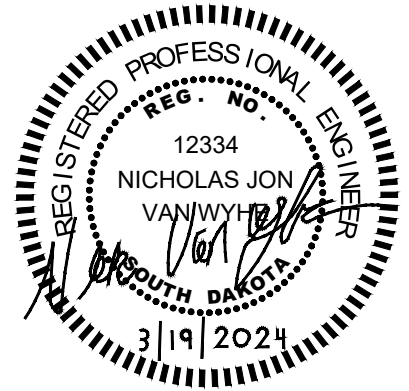

P:\Brookings\City of Brookings\2023-055 Brookings - Pickleball Courts\Design\Final Design\Alternates\2.dwg, Existing, 3/19/2024, 11:32 AM, Cole, Bungarden

P:\Brookings\Projects\City of Brookings\2023_055_Brookings - Pickleball Courts\Design\Final Design\Final Design - Pickleball Court\Increased Court Area\Details - EC Details_3/19/2024_11:30 AM_Cole_Bungard

MANUAL HIGH FLOW SILT FENCE INSTALLATION

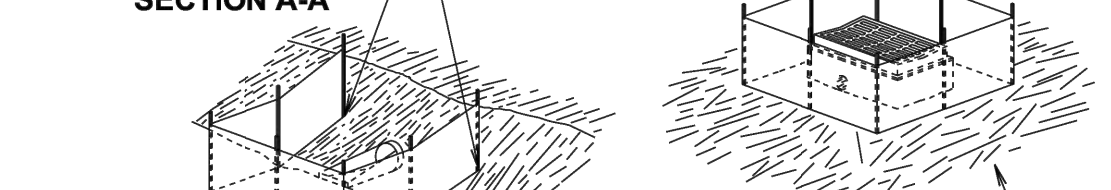
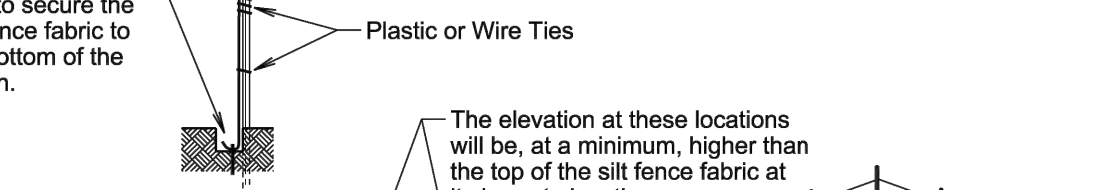
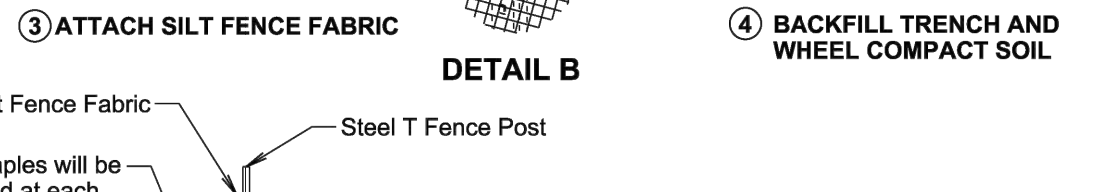
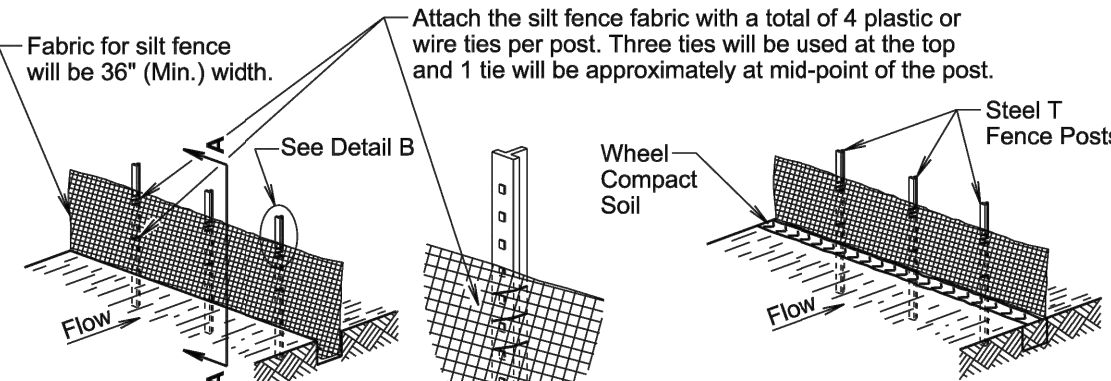

February 14, 2020

S D D O T	HIGH FLOW SILT FENCE	PLATE NUMBER 734.05
	<i>Published Date: 2024</i>	Sheet 1 of 2

MACHINE SLICED HIGH FLOW SILT FENCE INSTALLATION

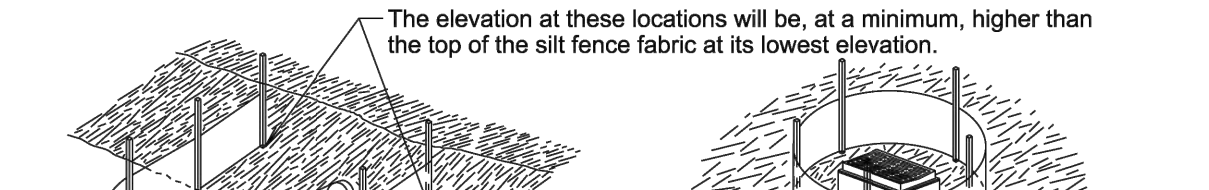
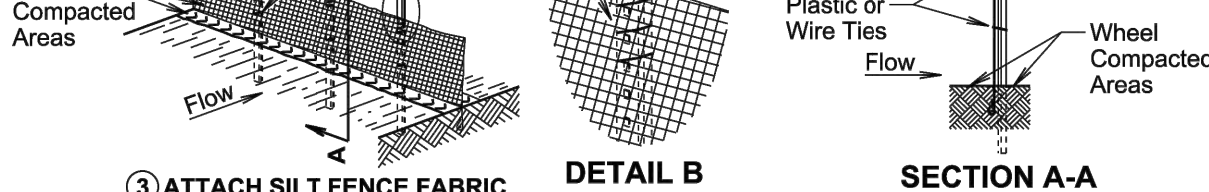
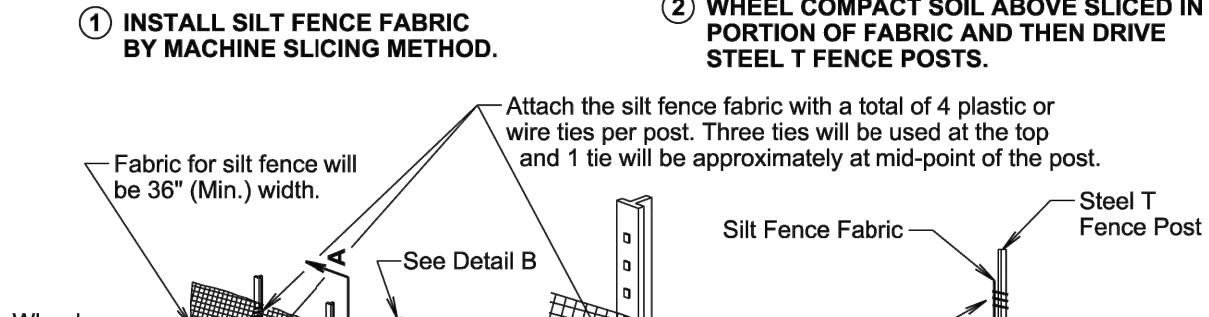
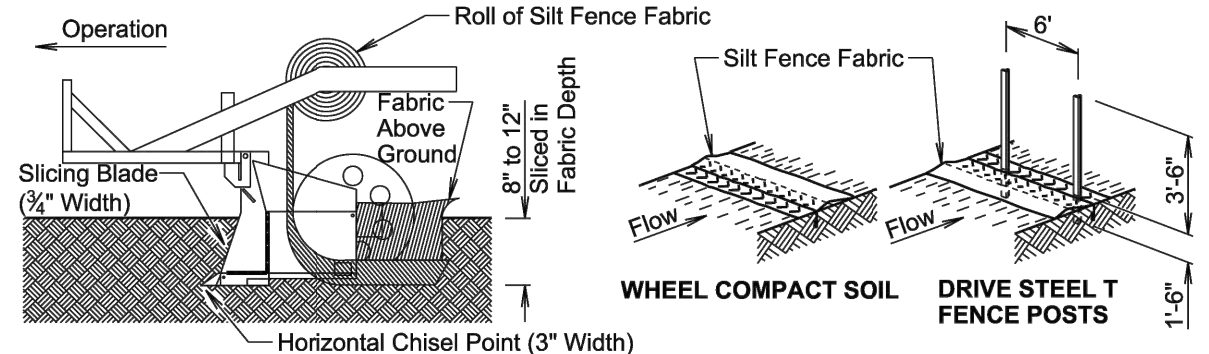

GENERAL NOTE:

If a trench can not be dug or the silt fence fabric can not be sliced in due to the type of earthen material (such as rock), then a row of 30 to 40 pound sandbags butted end to end will be provided on top of the extra length of silt fence fabric to prevent underflow.

February 14, 2020

S D D O T	HIGH FLOW SILT FENCE	PLATE NUMBER 734.05
	<i>Published Date: 2024</i>	Sheet 2 of 2

Proposed Site

Note: All Post-Tensioned Concrete Pavement to be Completed by a Certified Design-Build Contractor. Contractor Will be Required to Submit Design Submittal for Post-Tensioned Concrete Construction.



Scale: 1"=30'
 15 0 15 30

SITE LEGEND

	Proposed Concrete Surface
	Proposed Storm Sewer
	Proposed Drain Tile
	Proposed Area Inlet
	Proposed Lightpole Footing

KEYNOTE LEGEND

- (A) 48" Fence Gate (4' Height)
- (B) 28" - Fence (4' Height) Typ

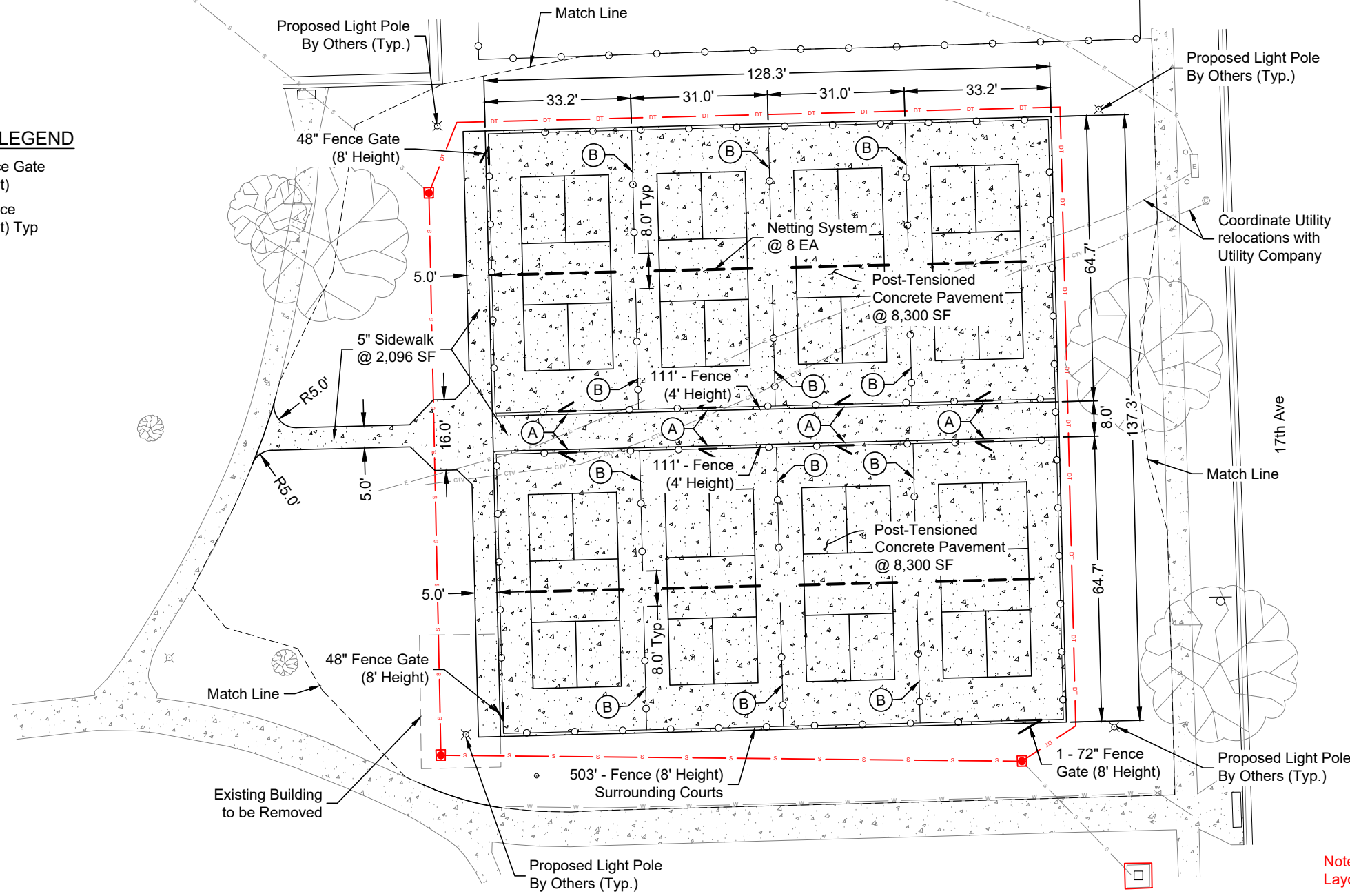

PARTIAL TABLE OF EST. QUANTITIES

DESCRIPTION	UNIT	QUANTITY
Scarify & Recompact (1-Ft)	CY	700
Non-Frost Susceptable Fill	TON	5,700
Aggregate Base Course	TON	550
5" Concrete Sidewalk	SF	2,096
Post-Tensioned Concrete Pavement	SF	16,600
Woven Geotextile Fabric	SY	2,020
Liquid Applied Acrylic Surface (2 Filler Layers, 2 Color Coats)	LS	Lump Sum
Court Marking and Striping	LS	Lump Sum
Netting System	EA	8
4' Black Vinyl Coated Chain-Link Fence	LF	558
48" Black Vinyl Coated Chain-Link Gate (4' Height)	EA	8
48" Black Vinyl Coated Chain-Link Gate (8' Height)	EA	2
72" Black Vinyl Coated Chain-Link Gate (8' Height)	EA	1
8' Black Vinyl Coated Chain-Link Fence	LF	503

Note: Plan Sheet Includes Revised Layout and Quantities.

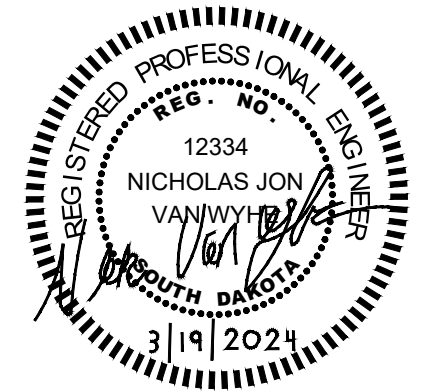

P:\Brookings\Projects\City of Brookings\2023_055 Brookings - Pickleball Courts\Design\Final Design\Alternates 2.dwg, Proposed 3/19/2024 11:32 AM, Cole Burgraden

Proposed Grading



Scale: 1"=30'
 15 0 15 30

SITE LEGEND

- 1606 --- Existing Contours
- 1606 — Proposed Contours
- EC: Edge of Concrete
- FL: Flow Line
- ← 2.02% Slope Arrow and Grade

PARTIAL TABLE OF EST. QUANTITIES

DESCRIPTION	UNIT	QUANTITY
Placing Topsoil (8")	CY	150
Permanent Seed Mixture	LB	95
Fertilizer	LB	190
Fiber Mulching	LB	680

Note: Seeding, Fertilizer, and Fiber Mulching areas to include all areas disturbed by grading extents.

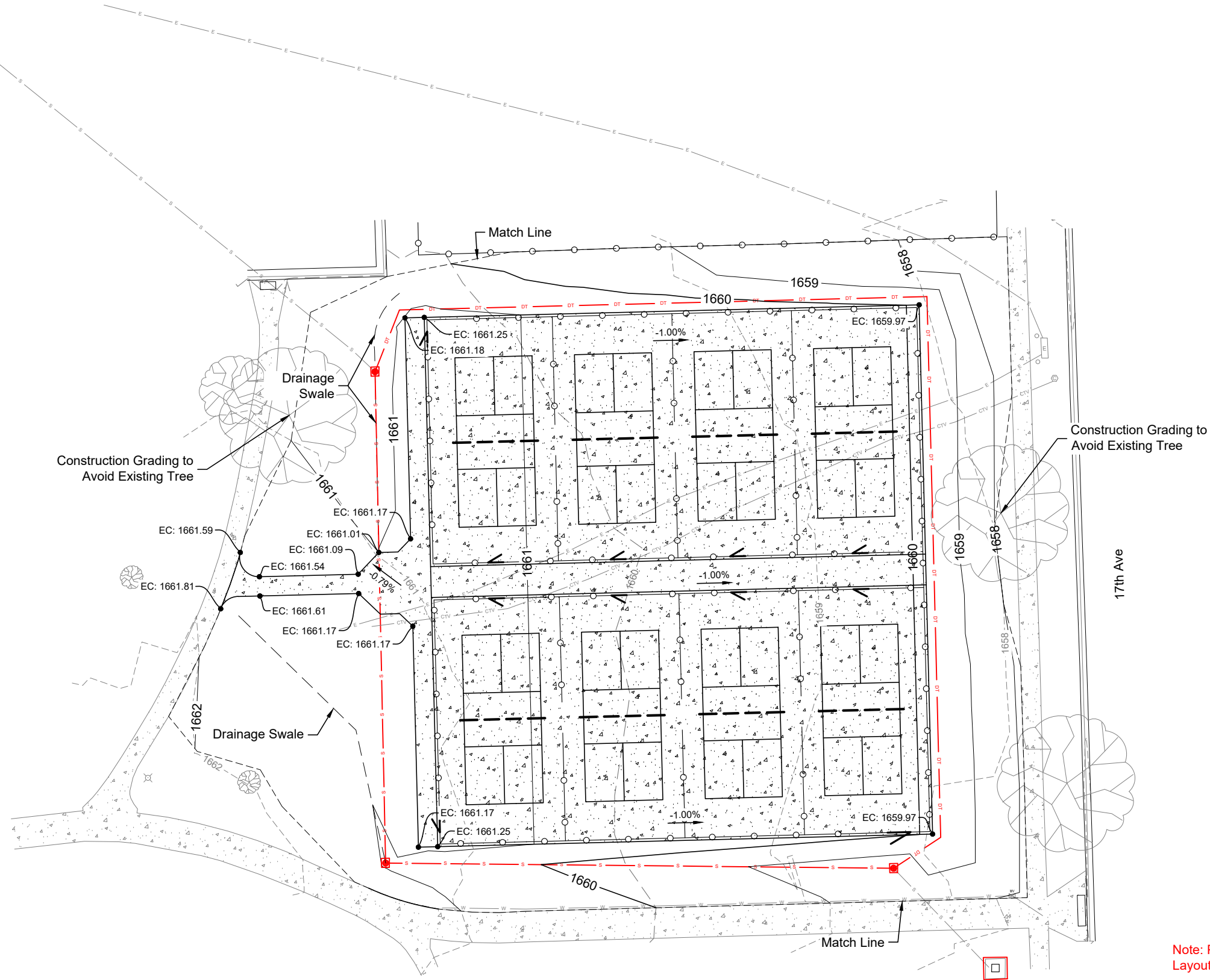

Note: Plan Sheet Includes Revised Layout and Quantities.

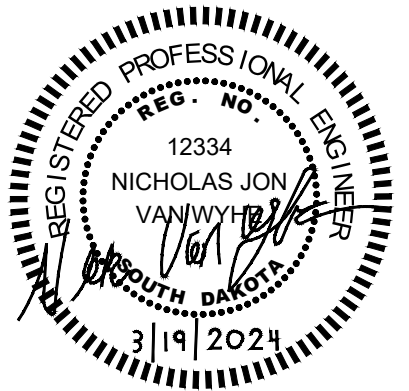

P:\Brookings\Projects\City of Brookings\2023_055 Brookings - Pickleball Courts\Design\Final Design\Alternates 2.dwg, Proposed Grading, 3/19/2024, 11:32 AM, Cole, Bungarden

Proposed Utilities



Scale: 1"=30'
 15 0 15 30

Storm Inlet
 Inv N: 1651.51 (15" PVC)
 Inv SE: 1651.66 (15" PVC)

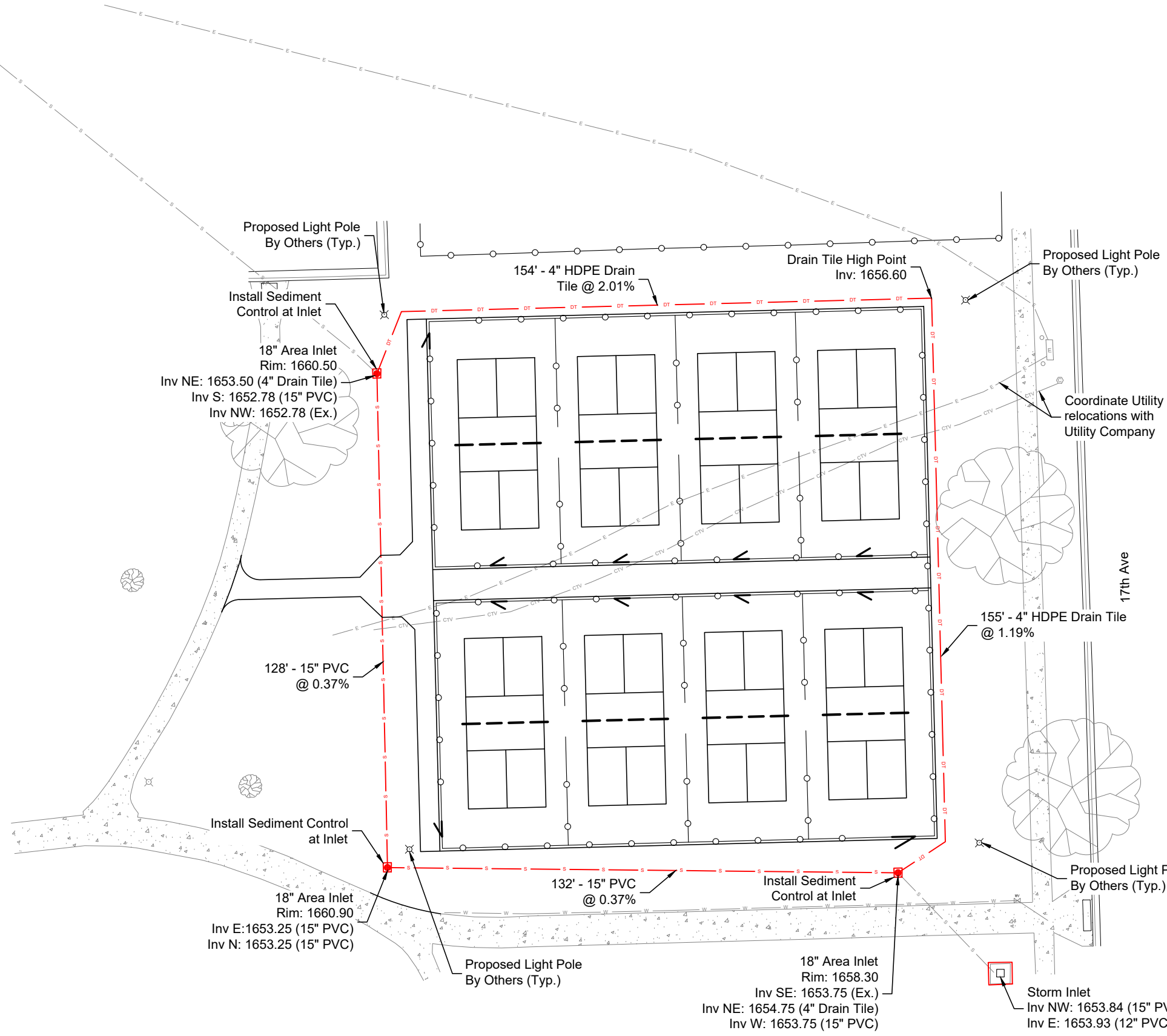

SITE LEGEND	
— W — W —	Water Line
— S — S —	Storm Sewer Line
— E — E —	Electric Line
— CTV — CTV —	Telephone Line
⊕	Water Valve
⊞	Elect Transformer
⊙	Light Pole
⊙	Cable Box
— S — S —	Proposed Storm Sewer
— DT — DT —	Proposed Drain Tile
●	Proposed Area Inlet
⊕	Proposed Lightpole Footing
□	Sediment Control at Inlets

PARTIAL TABLE OF EST. QUANTITIES		
DESCRIPTION	UNIT	QUANTITY
15" PVC, SDR 35, Furnish & Install	LF	260
18" Nyloplast Drain Basin W/ Grate, Furnish & Install	EA	3
4" HDPE Drain Tile w/Sock, Furnish & Install	LF	309
Inlet Sediment Control Device	EA	3

Note: Plan Sheet Includes Revised Layout and Quantities.

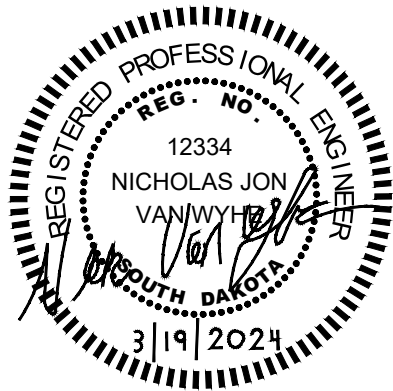

P:\Brookings\Projects\City of Brookings\2023_055\Brookings - Pickleball Courts\Design\Final Design\Alternates 2.dwg, Proposed Utilities, 3/19/2024 11:32 AM, Cole Bungarden

Details

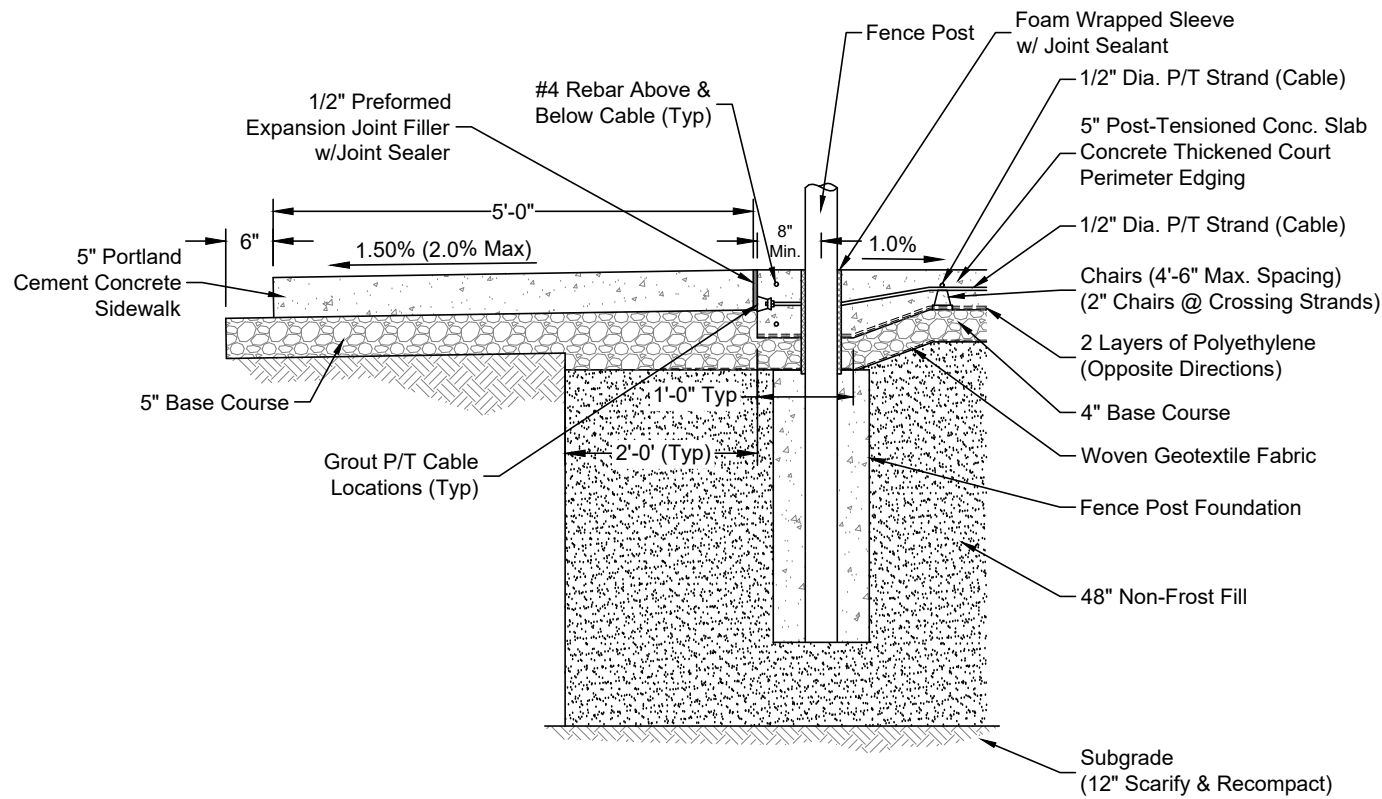

Edge Section of Post-Tensioned Concrete Court Pavement & Adjacent Sidewalk

Scale: 1/2" = 1'-0"

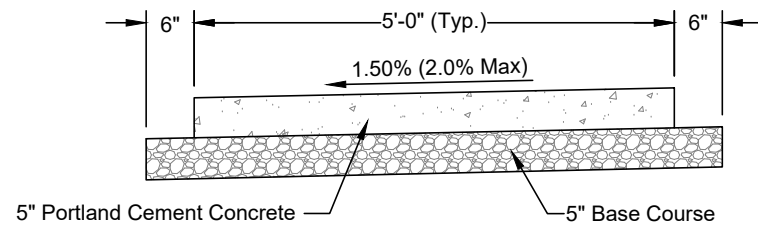

Sidewalks

Scale: 1/2" = 1'-0"

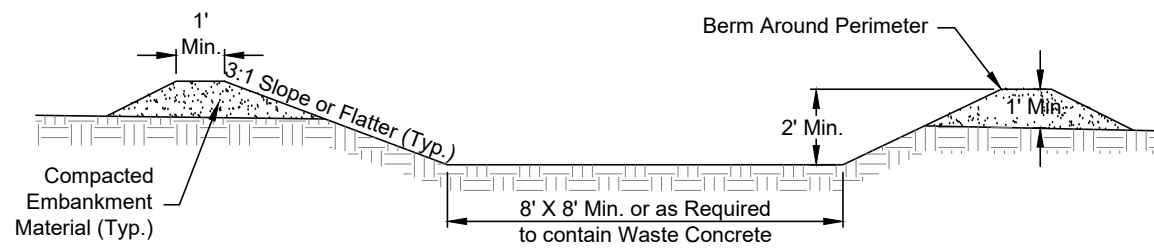

**Cross Sectional View
Concrete Washout Facility**

Scale: None

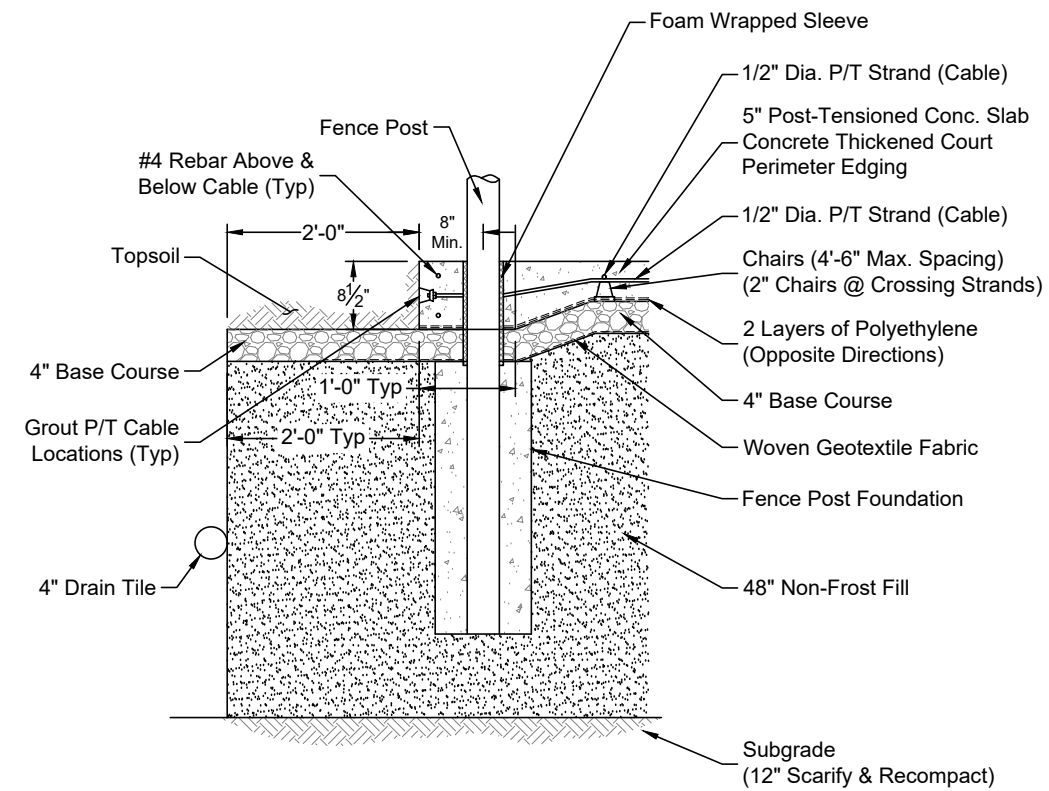

Edge Section of Post-Tensioned Concrete Court Pavement

Scale: 1/2" = 1'-0"

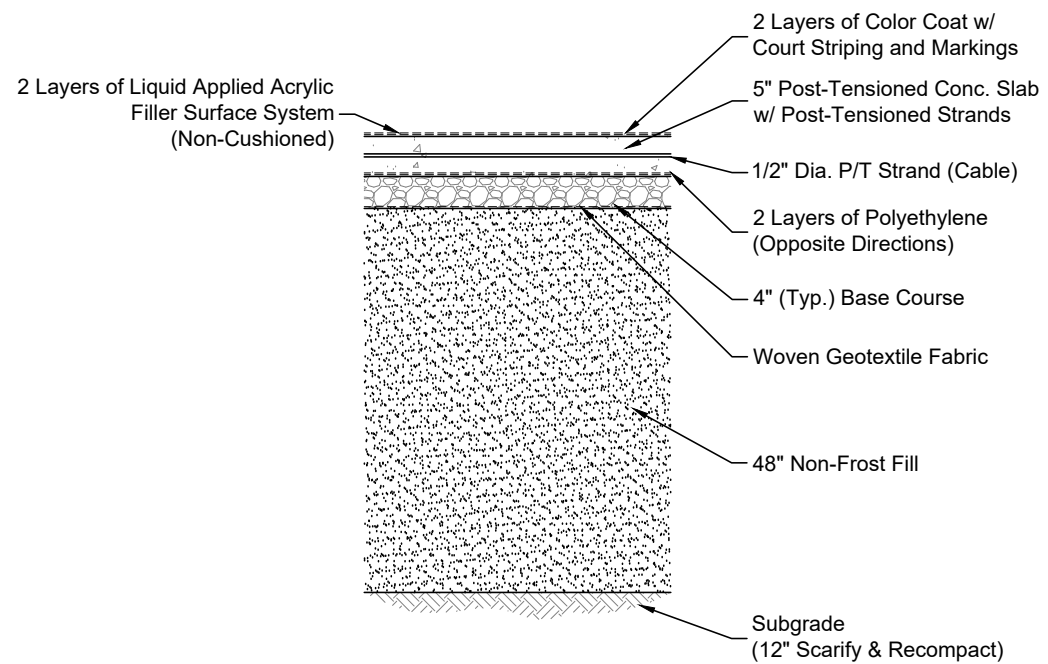

Post-Tensioned Concrete Court Pavement Section

Scale: 1/2" = 1'-0"



P:\Brookings\Projects\City of Brookings\2023_055\Brookings - Pickleball Courts\Design\Final Design\Final Design\Layout\Increased Court Area\Details_Final.dwg, Date: 3/19/2024, 11:30 AM, Cole Bangertsen

Details

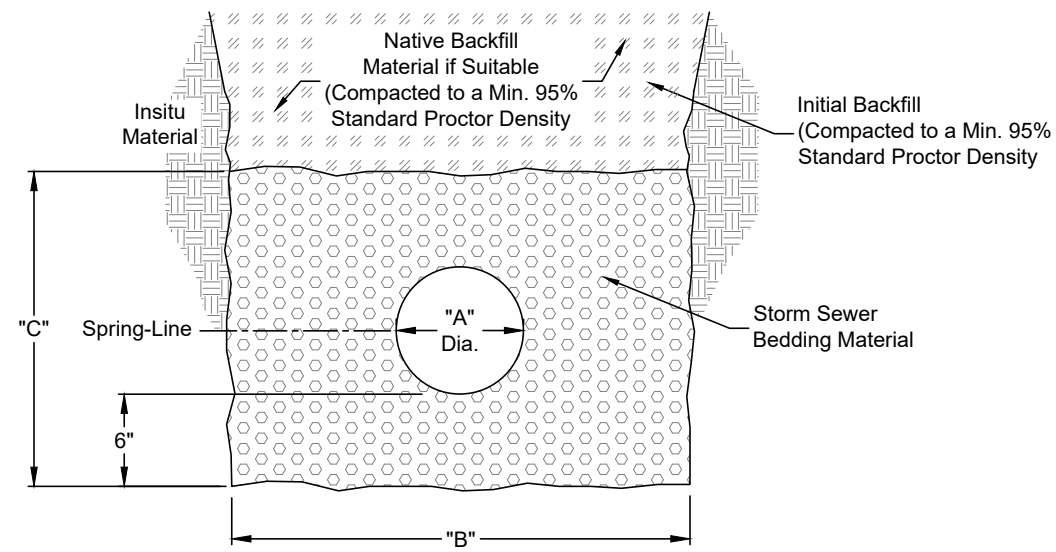

Pipe Size Diameter (A)	Trench Width (B)	Trench Height (C)	Trench Area	Pipe Area	Water Main Bedding Mat. Area	Water Main Bedding Mat. **Tons/LF
4"	28"	16"	3.11 Sq.Ft.	.09 Sq.Ft.	3.02 Sq.Ft.	0.18
6"	30"	18"	3.75 Sq.Ft.	.20 Sq.Ft.	3.55 Sq.Ft.	0.21
8"	32"	20"	4.44 Sq.Ft.	.35 Sq.Ft.	4.10 Sq.Ft.	0.25
10"	34"	22"	5.19 Sq.Ft.	.55 Sq.Ft.	4.65 Sq.Ft.	0.28
12"	36"	24"	6.00 Sq.Ft.	.79 Sq.Ft.	5.22 Sq.Ft.	0.31
15"	39"	27"	7.31 Sq.Ft.	1.23 Sq.Ft.	6.09 Sq.Ft.	0.37
18"	42"	30"	8.75 Sq.Ft.	1.77 Sq.Ft.	6.98 Sq.Ft.	0.42
21"	45"	33"	10.31 Sq.Ft.	2.41 Sq.Ft.	7.91 Sq.Ft.	0.47
24"	48"	36"	12.00 Sq.Ft.	3.14 Sq.Ft.	8.86 Sq.Ft.	0.53
27"	51"	39"	13.81 Sq.Ft.	3.98 Sq.Ft.	9.84 Sq.Ft.	0.59
30"	54"	42"	15.75 Sq.Ft.	4.91 Sq.Ft.	10.84 Sq.Ft.	0.65
36"	60"	48"	20.00 Sq.Ft.	7.07 Sq.Ft.	12.93 Sq.Ft.	0.78

* Length based on one (1) foot of Storm Sewer Pipe.

** Tons per LF is based on (120 lbs/ft³)

Pipe Bedding Detail Scale: None

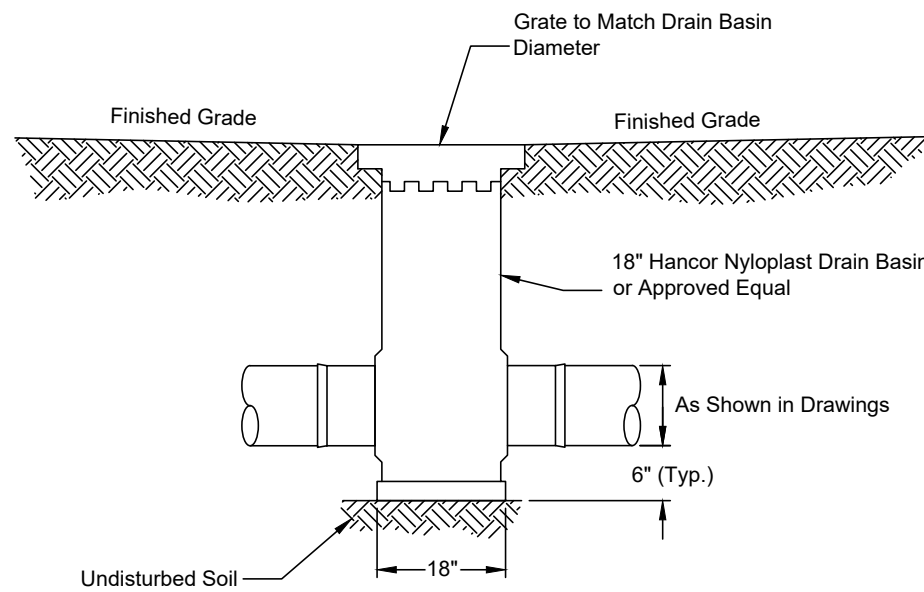

18" Drain Basin
Scale: None

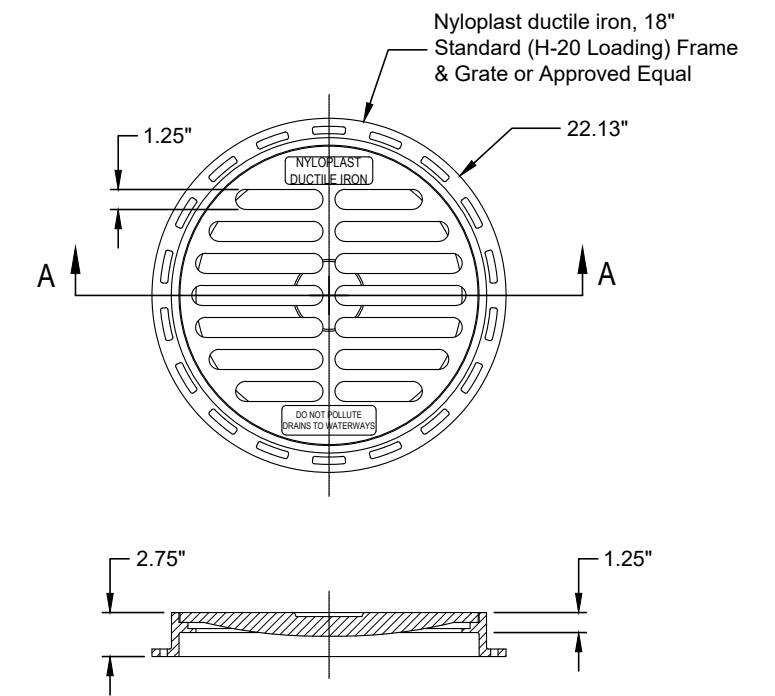

18" Frame & Grate Details
Scale: None

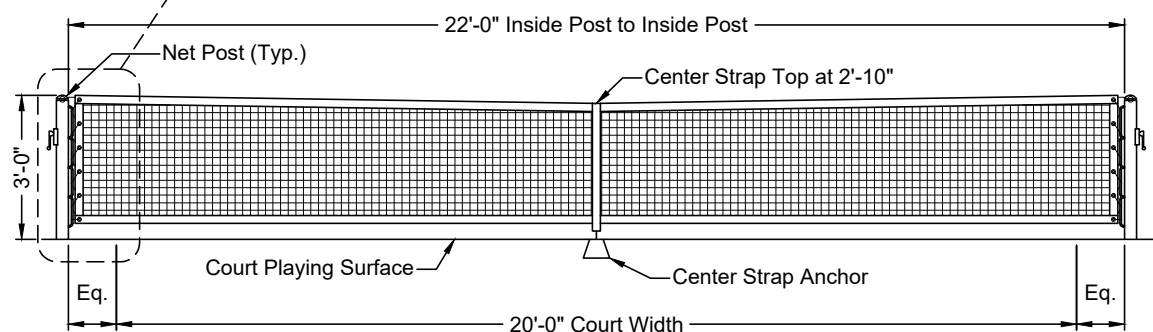
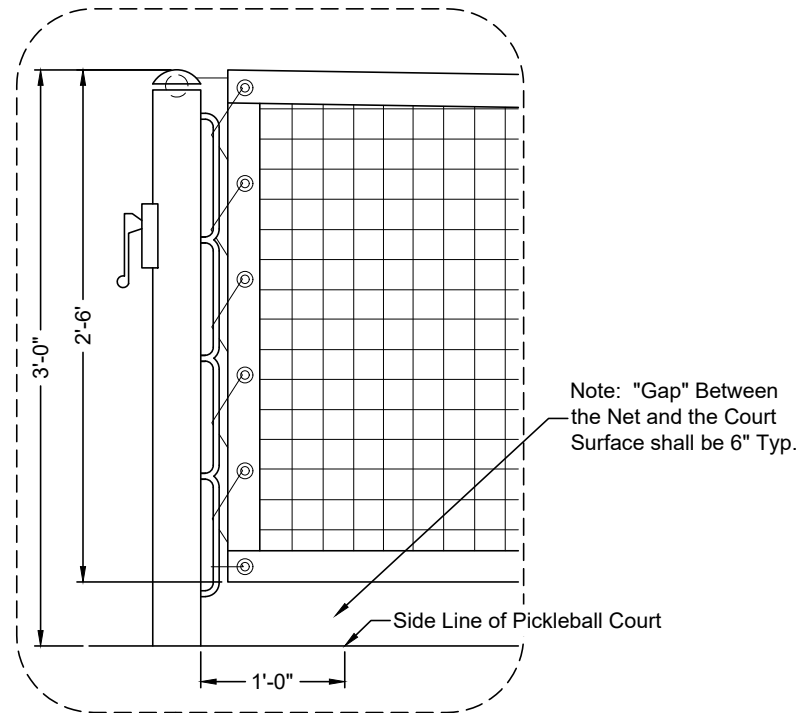

Pickleball Net Elevations
Scale: None

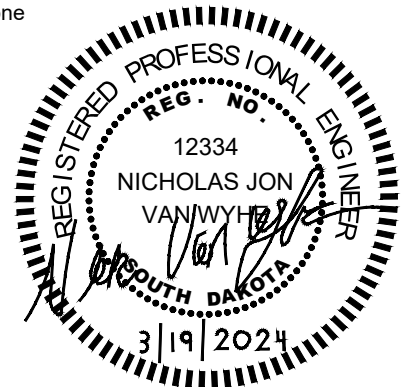

P:\Brookings\Projects\City of Brookings\2023_055 Brookings - Pickleball Courts\Design\Final Design\Final Design\Final Design - Alternate Layout Increased Court Area\Details_Final.dwg, Date: 3/19/2024, 11:30 AM, Cole Bungarden

Fence Details

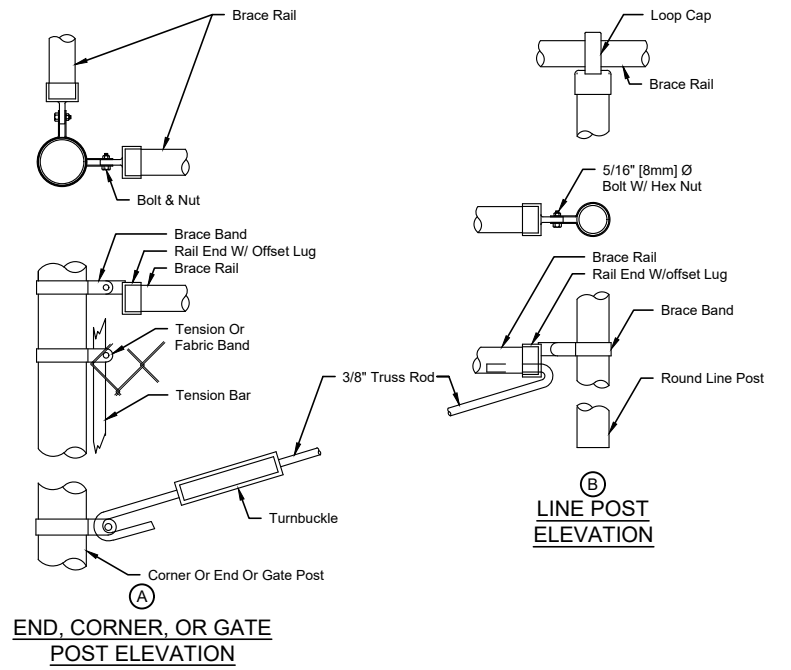
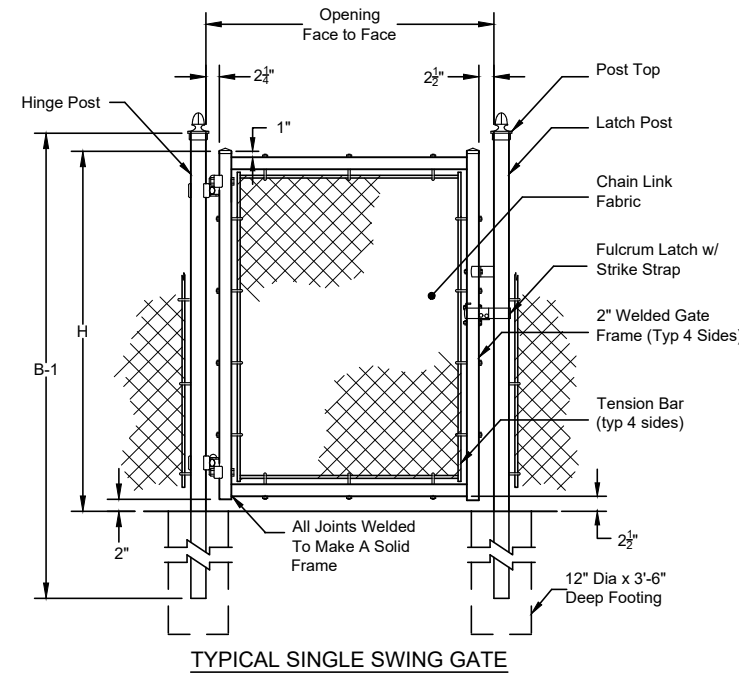
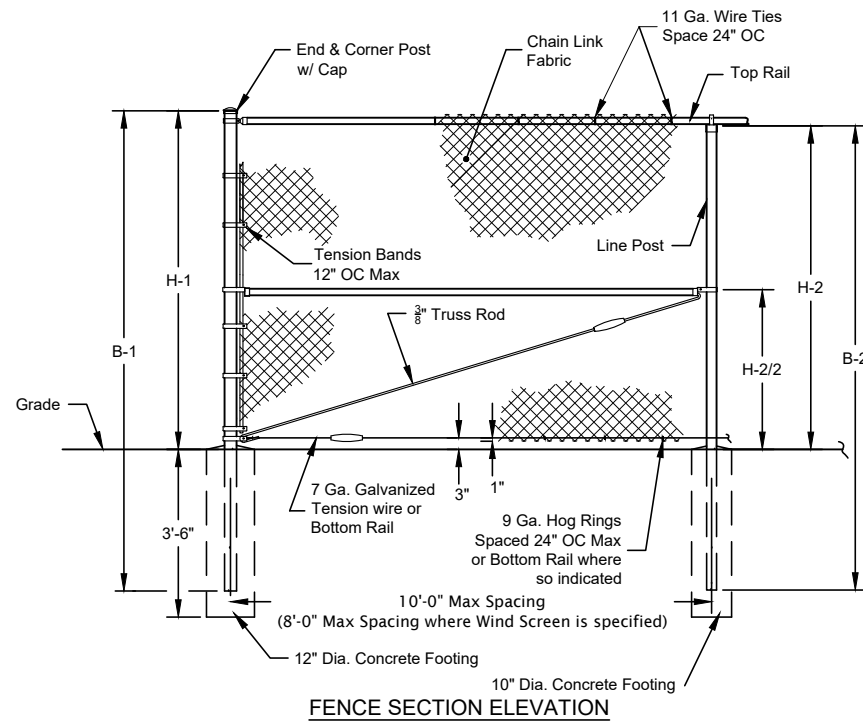

Notes:
 1. All Material To Conform To Federal Spec RR-G-191G (1-25-74).
 2. All Galvanized Fittings To Conform To ASTM-A153.

FENCE HEIGHT	END & CORNER POSTS		LINE POSTS	
	Nominal Height	B-1 Bar Length	H-1 Height Above Grade	B-2 Bar Length
4'-0"	7'-0"	4'-0 5/8"	6'-8"	3'-11"
8'-0"	11'-0"	8'-0 5/8"	10'-8"	7'-8 7/8"

Note:
 8-ft high fence gates shall be installed with a mid-rail on fencing frame.

Note:
 4-ft fence shall be installed to have wire flush with top-rail.

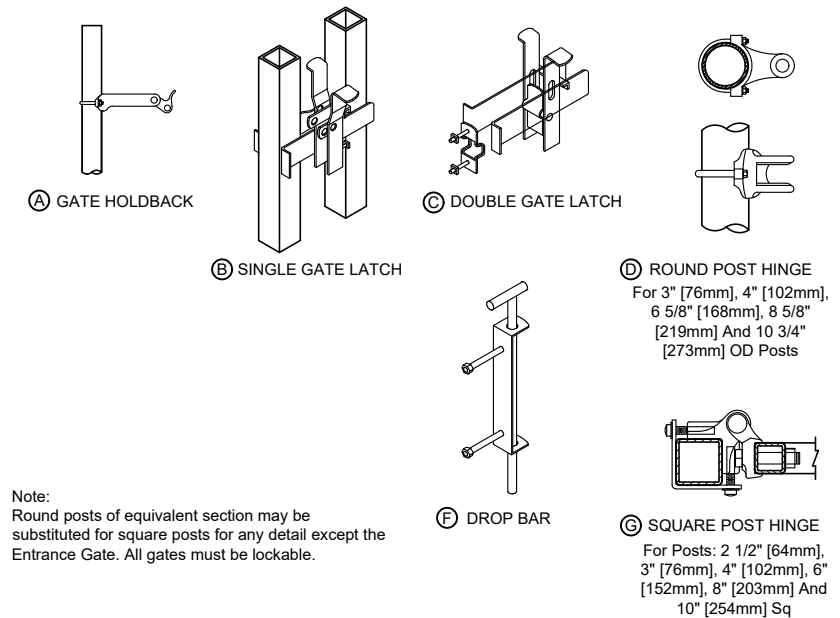

Note:
 Round posts of equivalent section may be substituted for square posts for any detail except the Entrance Gate. All gates must be lockable.

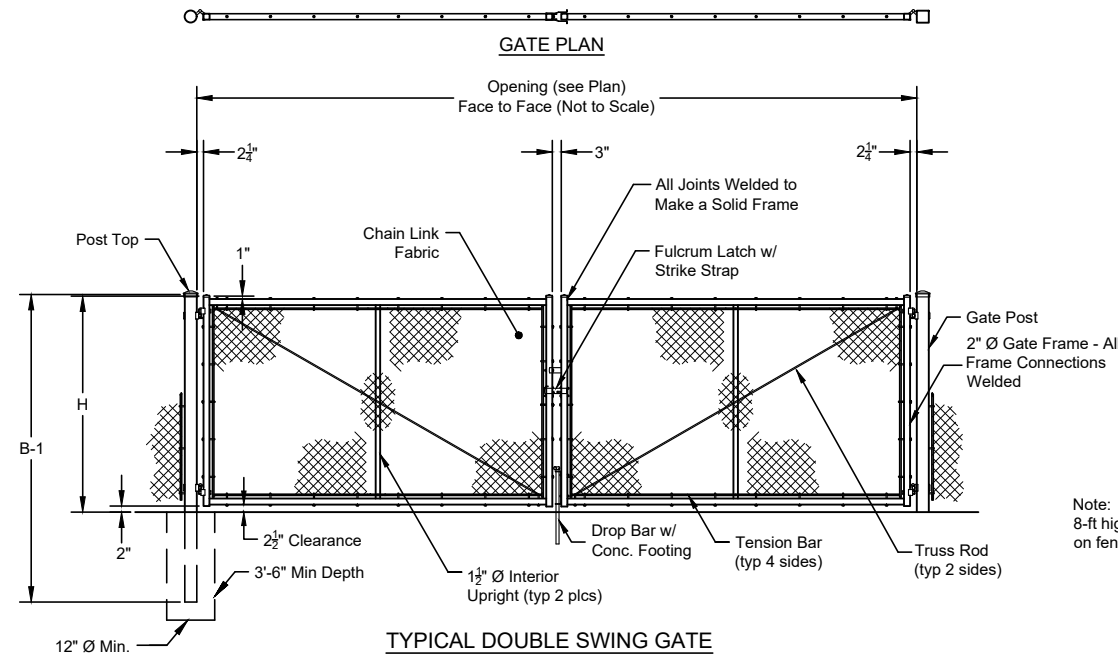

Note:
 8-ft high fence gates shall be installed with a mid-rail on fencing frame.

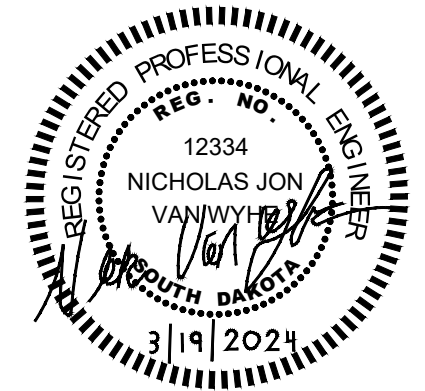

P:\Brookings\Projects\City of Brookings\2023_055 Brookings - Pickleball Courts\Design\Final Design\Final Design\Fence Details\Fence Details.dwg, 3/19/2024, 11:30 AM, Cole Bunnigarden